

HEAVY DUTY AIR NEEDLE SCALER

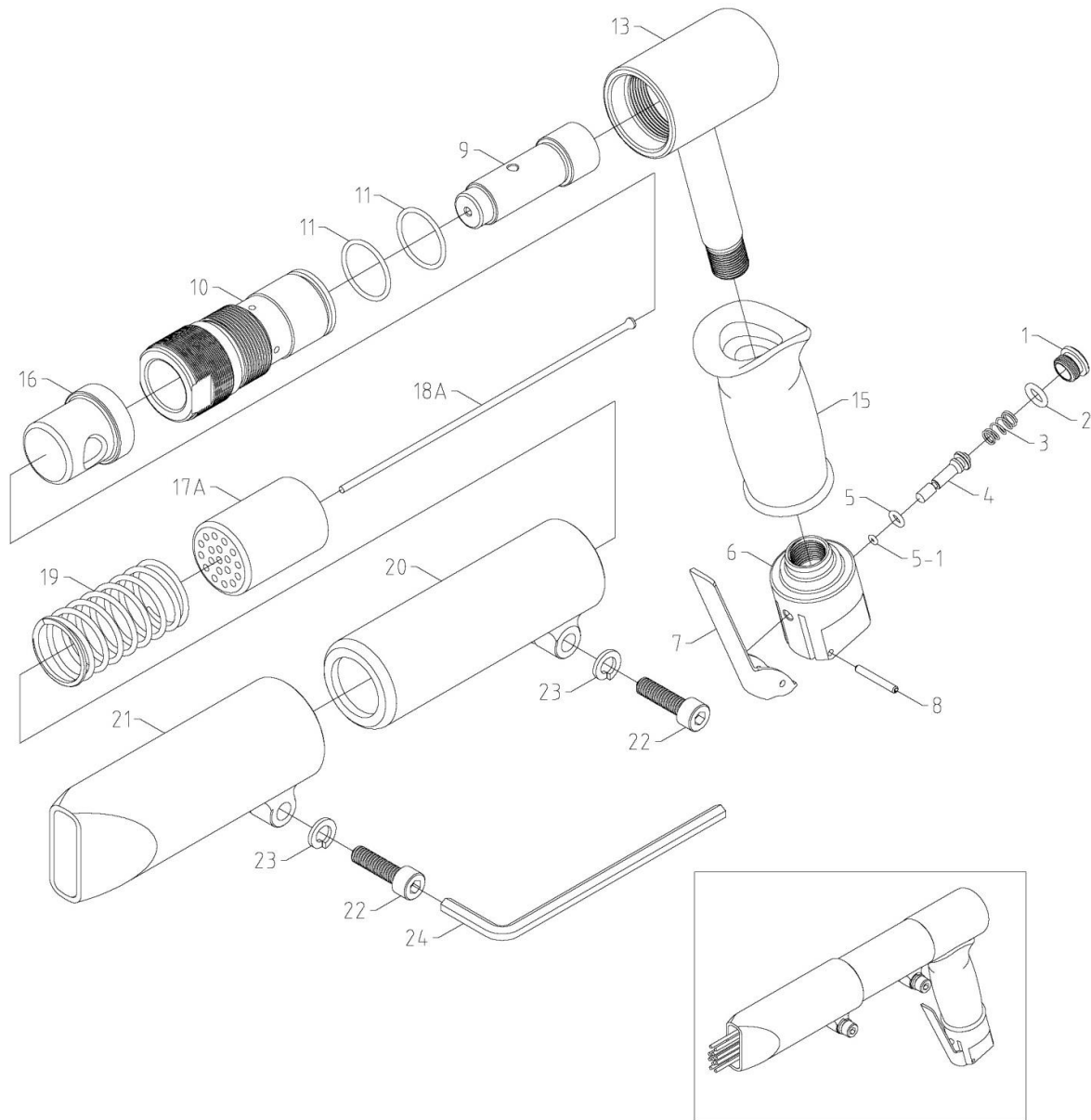

4722-P

INDEX NO.	DESCRIPTION	REQ'D NO.	INDEX NO.	DESCRIPTION	REQ'D NO.
01	Valve Cap	1	15	Rubber Grip	1
02	O-Ring	1	16	Needle Driver	1
03	Valve Spring	1	17A	Needle Holder (Ø 3×19 Holes)	1
04	Valve Stem	1	17B	Needle Holder (Ø 2×29 Holes) (Option)	1
05	O-Ring	1	18A	Needle (Ø 3×180L)	19
05-1	O-Ring	1	18B	Needle (Ø 2×180L) (Option)	29
06	Backhead	1	19	Compression Spring	1
07	Lever	1	20	Intermediate Tube	1
08	Spring Pin	1	21	Front Tube	1
09	Piston	1	22	Cap Head Screw	2
10	Cylinder	1	23	Spring Washer	2
11	O-Ring	2	24	Hex. Wrench (6mm)	1
13	Handle	1			

0000.00.00

2017.09.27 2019.07.17