

1/2" SQ. DR. SUPER DUTY IMPACT WRENCH

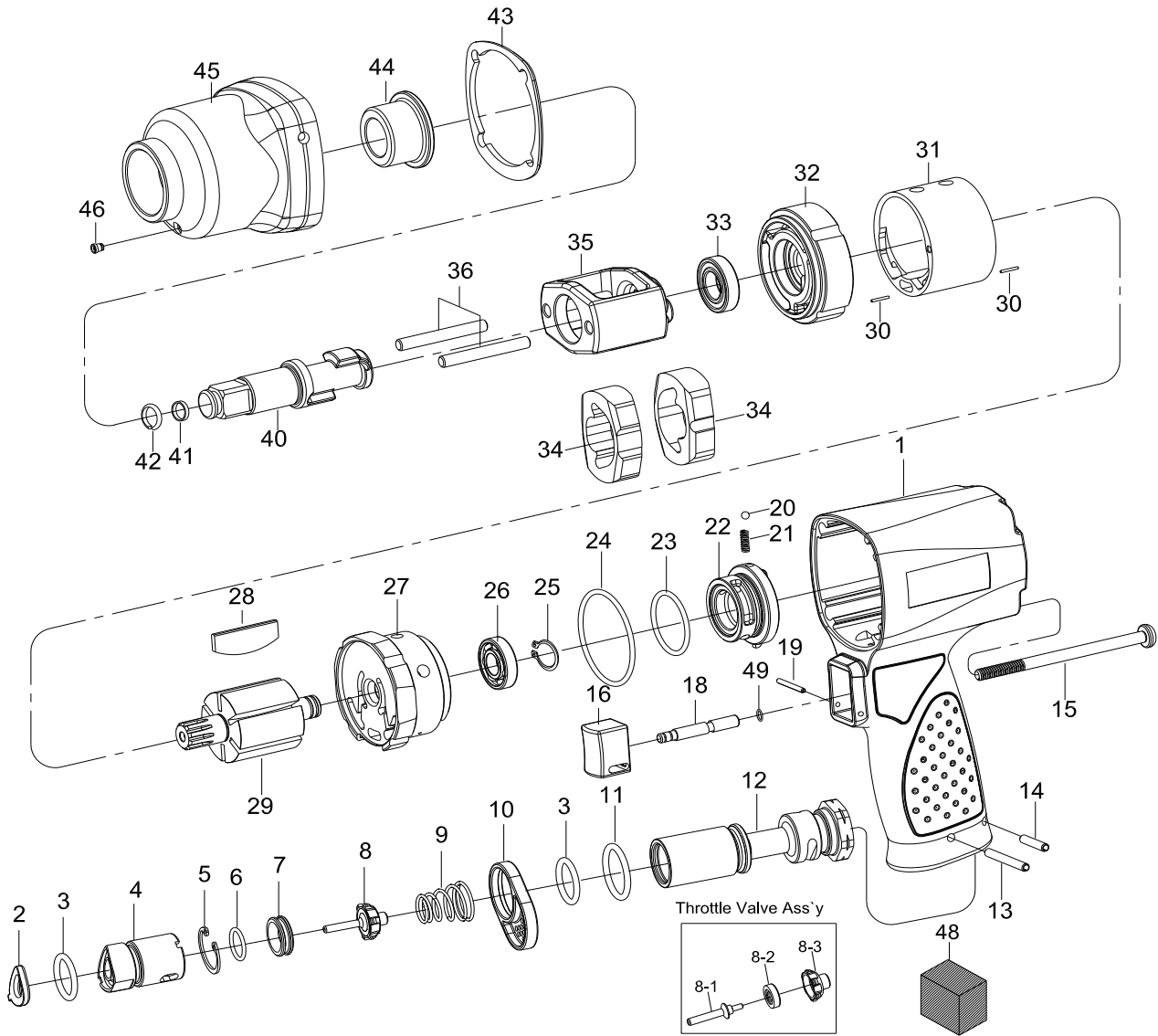

1355

INDEX NO.	DESCRIPTION	REQ'D NO.	INDEX NO.	DESCRIPTION	REQ'D NO.
1	Motor Housing	1	23	O-Ring	1
2	O-Ring	1	24	O-Ring	1
3	O-Ring	2	25	Retainer	1
4	Guide Tube	1	26	Ball Bearing	1
5	Retainer	1	27	Rear End Plate	1
6	O-Ring	1	28	Rotor Blade	6
7	Throttle Valve Seat	1	29	Rotor	1
★ 8	Throttle Valve Assembly (incl. 8-1.8-2.8-3)	1	30	Spring Pin	2
● 8-1	Throttle Valve Pin	1	31	Cylinder	1
● 8-2	Rubber Seal	1	32	Front End Plate	1
● 8-3	Throttle Valve	1	33	Ball Bearing	1
9	Spring	1	34	Hammer	2
10	Exhaust Deflector	1	35	Hammer Frame	1
11	O-Ring	1	36	Hammer Pin	2
12	Air Inlet	1	40	Standard Anvil	1
13	Spring Pin	1	41	O-Ring	1
14	Spring Pin	1	42	Socket Retainer	1
15	Screw	4	43	Gasket	1
★ 16	Trigger Assembly (incl. 18.49)	1	● 44	Bushing	1
● 18	Trigger Pin	1	★ 45	Hammer Case Assembly (incl. 44.46)	1
19	Spring Pin	1	● 46	Grease Fitting	1
20	Steel Ball	1	48	Muffer Element	1
21	Spring	1	● 49	O-Ring	1
22	Reverse Valve	1	TK	Tune-Up Kit { incl. 3 (2) .6.9.11.20.21.23.24.26.28 (6) .33.41.42.43.48.49 }	

★ Must be Purchased in Assembly Set

● Recommended not to be purchased alone due to assembly difficulty

20121108R2