

1/2" SQ. DR. SUPER DUTY IMPACT WRENCH

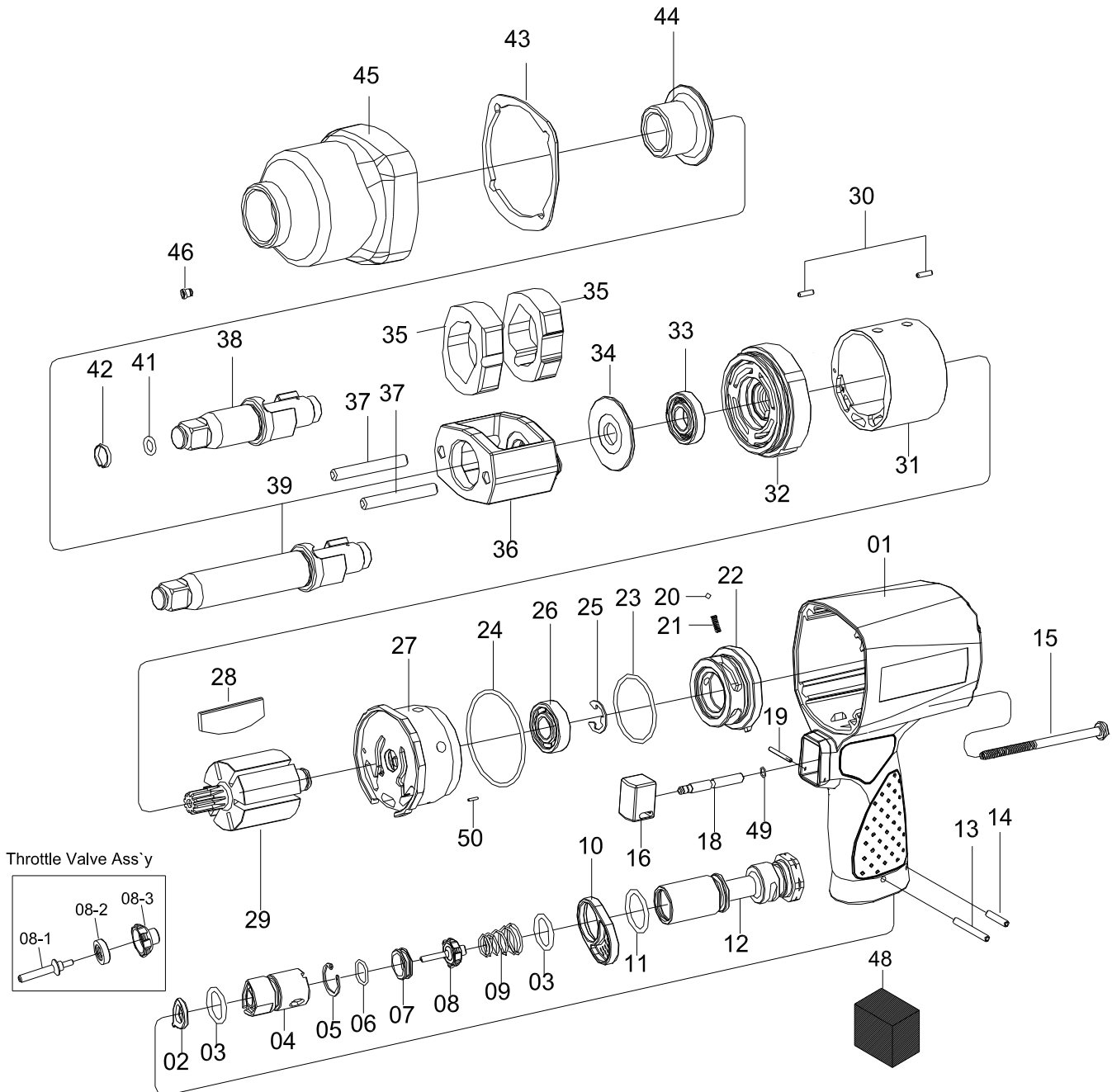

1454MT/1454MT-2

INDEX NO.	DESCRIPTION	REQ'D NO.	INDEX NO.	DESCRIPTION	REQ'D NO.
1	Motor Housing	1	25	Retainer	1
2	O-Ring	1	26	Ball Bearing	1
3	O-Ring	2	27	Rear End Plate	1
4	Guide Tube	1	28	Rotor Blade	6
5	Retainer	1	29	Rotor	1
6	O-Ring	1	30	Spring Pin	2
7	Throttle Valve Seat	1	31	Cylinder	1
★ 8	Throttle Valve Assembly (incl.8-1.8-2.8-3)	1	32	Front End Plate	1
● 8-1	Throttle Valve Pin	1	33	Ball Bearing	1
● 8-2	Rubber Seal	1	34	Washer	1
● 8-3	Throttle Valve	1	35	Hammer	2
9	Spring	1	36	Hammer Frame	1
10	Exhaust Deflector	1	37	Hammer Pin	2
11	O-Ring	1	38	Standard Anvil (for KI-1454MT)	1
12	Air Inlet	1	39	2" Extended Anvil (for KI-1454MT-2)	1
13	Spring Pin	1	41	O-Ring	1
14	Spring Pin	1	42	Socket Retainer	1
15	Screw	4	43	Gasket	1
★ 16	Trigger Assembly (incl.18.49)	1	● 44	Bushing	1
● 18	Trigger Pin	1	★ 45	Hammer Case Assembly (incl.44.46)	1
19	Spring Pin	1	● 46	Grease Fitting	1
20	Steel Ball	1	48	Muffler Element	1
21	Spring	1	● 49	O-Ring	1
22	Reverse Valve	1	50	Pin	1
23	O-Ring	1	TK	Tune-Up Kit { incl.3 (2).6.9.11.20.21.23.24.26.28 (6).33.	
24	O-Ring	1		41.42.43.48.49 }	

★ Must be Purchased in Assembly Set

● Recommended not to be purchased alone due to assembly difficulty

20131211R2