

# 1/2" SQ. DR. SUPER DUTY IMPACT WRENCH

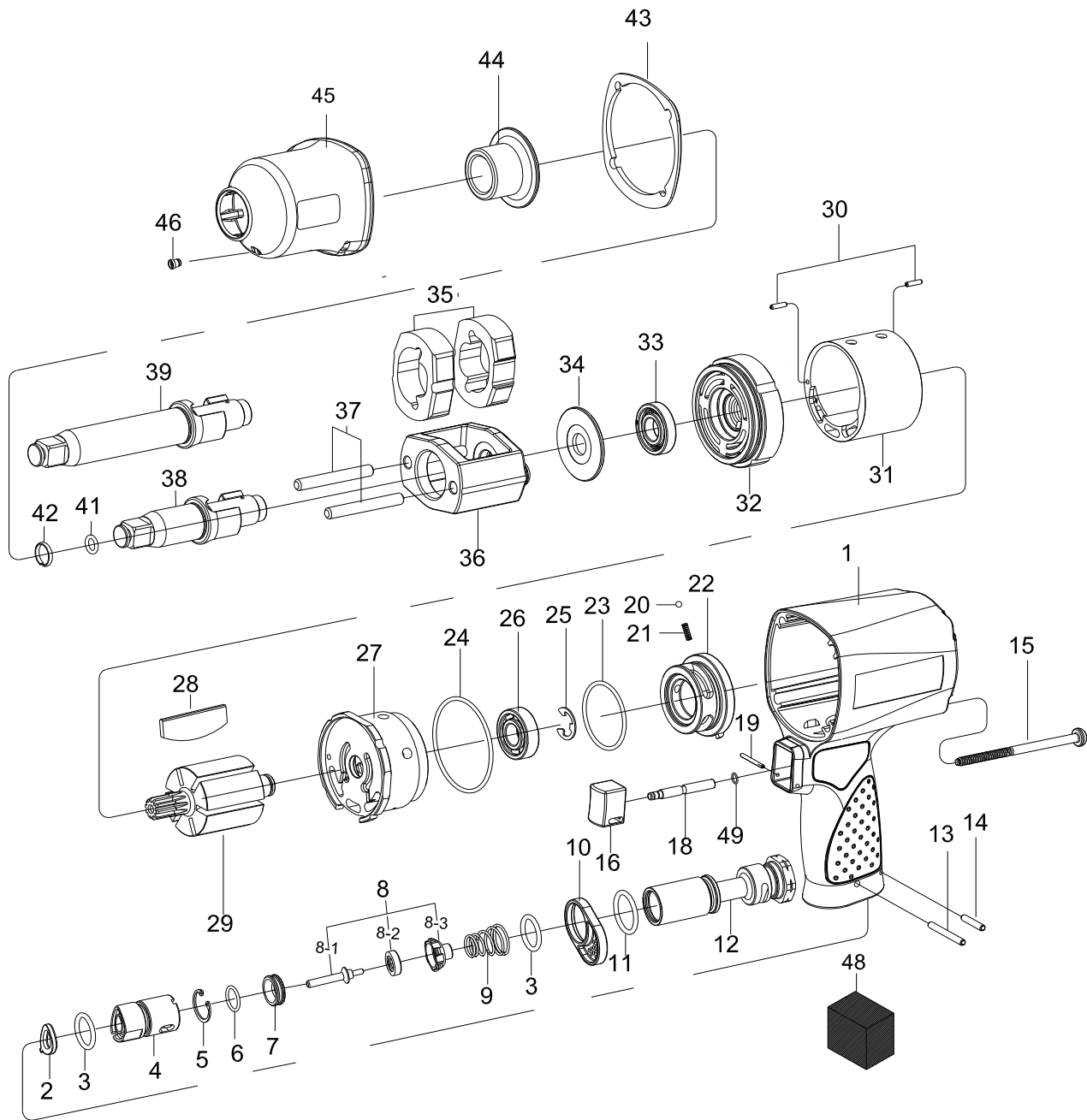

## 1454TI/1454TI-2

INDEX NO.	DESCRIPTION	REQ'D NO.	INDEX NO.	DESCRIPTION	REQ'D NO.
1	Motor Housing	1	24	O-Ring	1
2	O-Ring	1	25	Retainer	1
3	O-Ring	2	26	Ball Bearing	1
4	Guide Tube	1	27	Rear End Plate	1
5	Retainer	1	28	Rotor Blade	6
6	O-Ring	1	29	Rotor	1
7	Throttle Valve Seat	1	30	Spring Pin	2
★ 8	Throttle Valve Assembly ( incl.8-1.8-2.8-3 )	1	31	Cylinder	1
● 8-1	Throttle Valve Pin	1	32	Front End Plate	1
● 8-2	Rubber Seal	1	33	Ball Bearing	1
● 8-3	Throttle Valve	1	34	Washer	1
9	Spring	1	35	Hammer	2
10	Exhaust Deflector	1	36	Hammer Frame	1
11	O-Ring	1	37	Hammer Pin	2
12	Air Inlet	1	38	Standard Anvil ( for KI-1454TI )	1
13	Spring Pin	1	39	2" Extended Anvil ( for KI-1454TI-2 )	1
14	Spring Pin	1	41	O-Ring	1
15	Screw	4	42	Socket Retainer	1
★ 16	Trigger Assembly ( incl.18.49 )	1	43	Gasket	1
● 18	Trigger Pin	1	● 44	Bushing	1
19	Spring Pin	1	★ 45	Hammer Case Assembly ( incl.44.46 )	1
20	Steel Ball	1	● 46	Grease Fitting	1
21	Spring	1	48	Muffler Element	1
22	Reverse Valve	1	● 49	O-Ring	1
23	O-Ring	1	TK	Tune-Up Kit { 3 ( 2 ),6.9.11.20.21.23.24.26.28 ( 6 ),33.41.42.43.48.49 }	

★ Must be Purchased in Assembly Set

● Recommended not to be purchased alone due to assembly diff

PA1-01454TI-2

20090413R1