

3/4" SQ. DR. SUPER DUTY AIR IMPACT WRENCH

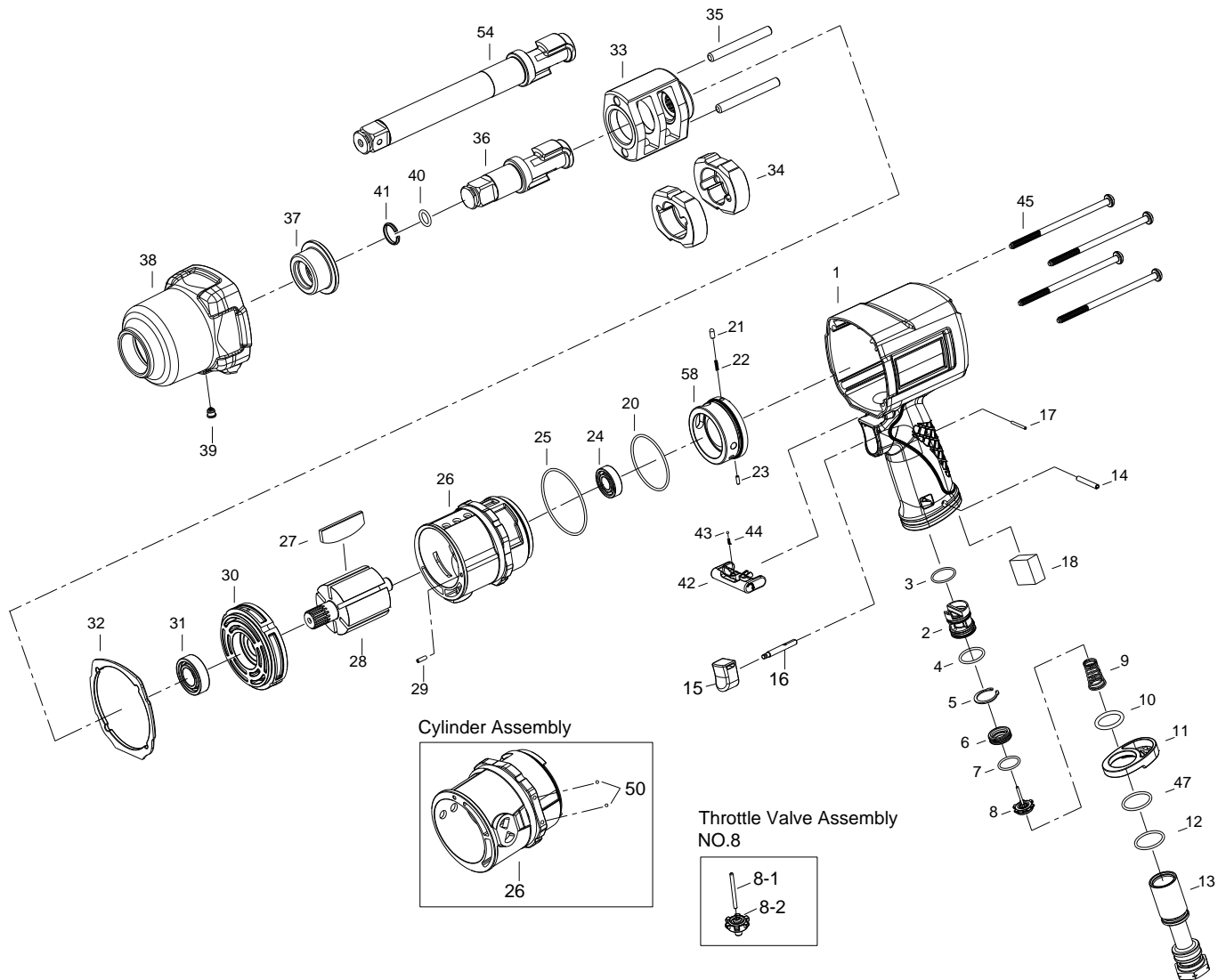

1680_1680-6

INDEX NO.	DESCRIPTION	REQ'D NO.	INDEX NO.	DESCRIPTION	REQ'D NO.
1	Motor Housing	1	★ 26	Cylinder Assembly { incl.50 (2) }	1
2	Reverse Valve	1	27	Rotor Blade	6
3	O-Ring	1	28	Rotor	1
4	O-Ring	1	29	Spring Pin	1
5	Retainer	1	30	Front End Plate	1
6	Throttle Valve Seat	1	31	Ball Bearing	1
7	O-Ring	1	32	Hammer Case Gasket	1
★ 8	Throttle Valve Assembly (incl.8-1.8-2)	1	33	Hammer Frame	1
● 8-1	Throttle Valve Pin	1	34	Hammer	2
● 8-2	Throttle Valve	1	35	Hammer Pin	2
9	Throttle Valve Spring	1	36	Standard Anvil (for KI-1680)	1
10	O-Ring	1	● 37	Bushing	1
11	Exhaust Deflector	1	★ 38	Hammer Case Assembly (incl.37.39)	1
12	O-Ring	1	● 39	Grease Fitting	1
13	Air Inlet	1	40	O-Ring	1
14	Spring Pin	1	41	Retainer	1
★ 15	Trigger Assembly (incl.16)	1	42	Reverse Knob	1
● 16	Trigger Pin	1	43	Steel Ball	1
17	Spring Pin	1	44	Spring	1
18	Muffler Element	1	45	Screw	4
20	O-Ring	1	47	O-Ring	1
21	Pin	1	● 50	Steel Ball	2
22	Spring	1	54	6" Extended Anvil (for 1680-6)	1
23	Spring Pin	1	58	Reverse Valve Knob	1
24	Ball Bearing	1	TK	Tune-Up Kit { incl.3.4.5.7.10.12.18.20.22.25.27 (6).32.40.41.43.44 }	
25	O-Ring	1			

★ Must be Purchased in Assembly Set

● Recommended not to be purchased alone due to assembly difficulty

20150131R2