

# 1/2" SQ.DR. SUPER DUTY RATCHET WRENCH

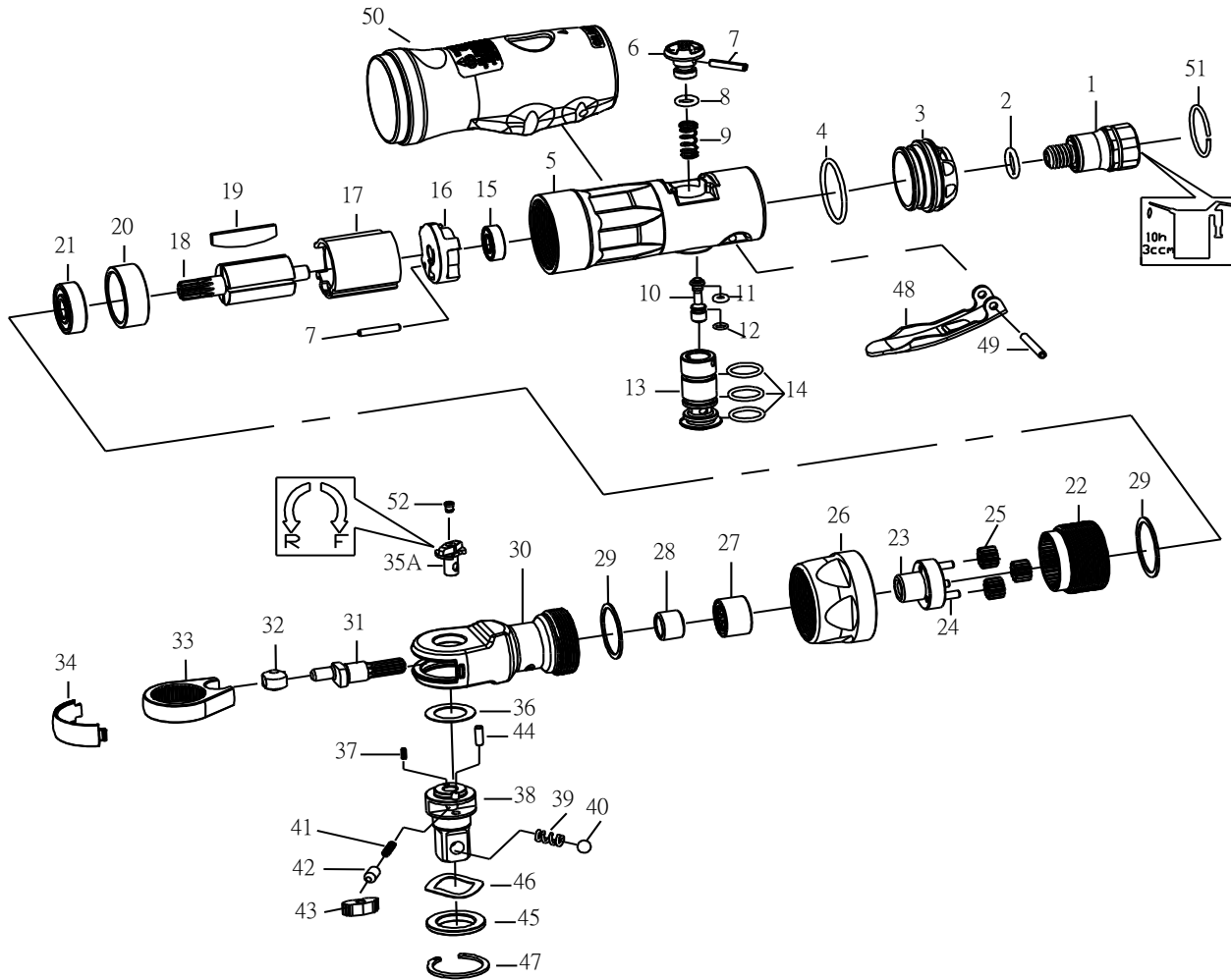

## 2407

INDEX NO.	DESCRIPTION	REQ'D NO.	INDEX NO.	DESCRIPTION	REQ'D NO.
1	Air Inlet	1	28	Bushing	1
2	O-Ring	1	29	Spacer	2
3	Exhaust Deflector	1	30	Ratchet Housing	1
4	O-Ring	1	31	Crank shaft	1
5	Motor Housing	1	32	Drive Bushing	1
6	Air Regulator	1	33	Ratchet Yoke	1
7	Spring Pin	2	34	Ratchet Housing Cover	1
8	O-Ring	1	★ 35A	Reverse Knob Assembly ( incl.52 )	1
9	Spring	1	36	Thrust Washer	1
10	Throttle Valve Plunger	1	37	Spring Pin	1
11	O-Ring	1	★ 38	Ratchet Anvil Assembly ( incl 39.40 )	1
12	O-Ring	1	● 39	Spring	1
13	Power Regulator	1	● 40	Steel Ball	1
14	O-Ring	3	41	Ratchet Spring	1
15	Ball Bearing	1	42	Ratchet Lock Pin	1
16	Rear End Plate	1	43	Ratchet Pawl	1
17	Cylinder	1	44	Pawl Retaining Pin	1
18	Rotor	1	45	Thrust Washer	1
19	Rotor Blade	4	46	Wave Washer	1
20	Front End Plate	1	47	Retaining Ring	1
21	Ball Bearing	1	48	Trigger	1
22	Ring Gear	1	49	Trigger Pin	1
★ 23	Work Spindle Assembly { incl.24 ( 3 ) }	1	50	Rubber Grip	1
● 24	Pin	3	51	Retainer	1
25	Planet Gear	3	● 52	Grease Fitting	1
26	Coupling Nut	1			
27	Needle Bearing	1	TK	Tune-Up Kit { 2.4.8.9.11.12.14 ( 3 ) }	

★ Must be Purchased in Assembly Set

● Recommended not to be purchased alone due to assembly difficul

PA2-02407-2

20090420R1