

1" SQ. DR.SUPER DUTY IMPACT WRENCH

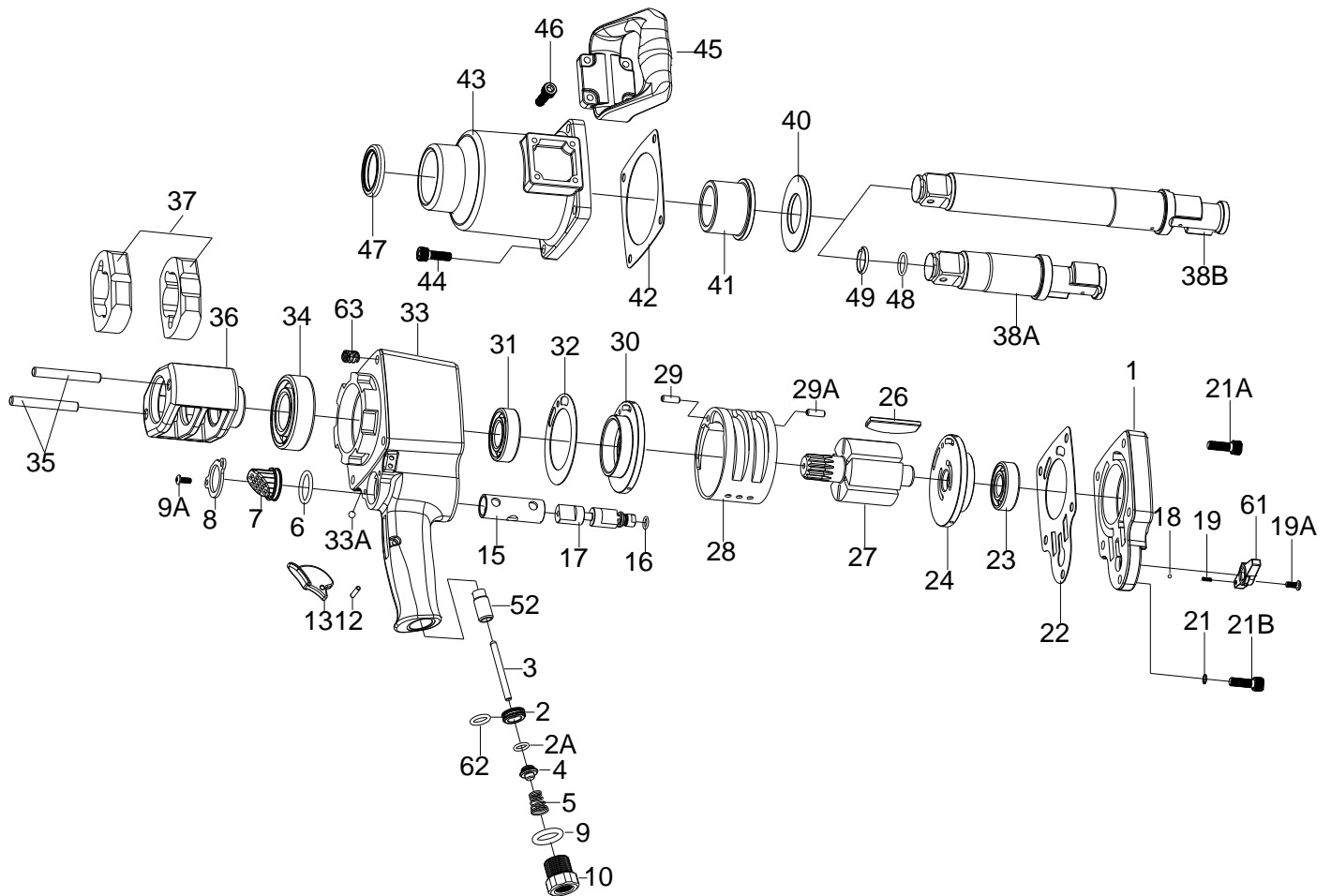

36P_36P-6

INDEX NO.	DESCRIPTION	REQ'D NO.	INDEX NO.	DESCRIPTION	REQ'D NO.
1	Backhead	1	29	Spring Pin	1
2	Throttle Valve Seat	1	29A	Spring Pin	1
2A	O-Ring	1	★ 30	Front End Plate Assembly (incl.31)	1
3	Throttle Valve Plunger	1	● 31	Ball Bearing	1
4	Throttle Valve	1	32	Gasket	1
5	Spring	1	★ 33	Housing Assembly { incl.15.33A (4) .52. 63 (9) }	1
6	O-Ring	1	● 33A	Steel Ball	4
7	Exhaust Deflector	1	34	Ball Bearing	1
8	Retainer	1	35	Hammer Pin	2
9	O-Ring	1	36	Hammer Frame	1
9A	Screw	2	37	Hammer	2
10	Air Inlet	1	38A	Standard Anvil (for KI-36P)	1
12	Trigger Pin	1	38B	6" Extended Anvil (for KI-36P-6)	1
13	Trigger	1	40	Washer	1
● 15	Reverse Valve Bushing	1	41	Bushing	1
16	O-Ring	1	42	Gasket	1
17	Reverse Valve	1	43	Hammer Case	1
18	Steel Ball	1	44	Screw	4
19	Spring	1	45	Side Spade Handle	1
19A	Screw	1	46	Screw	4
● 21	Spring Washer	1	47	Oil Seal	1
21A	Screw	4	48	O-Ring	1
★ 21B	Screw Assembly (incl.21)	1	49	Socket Retainer	1
22	Gasket	1	● 52	Bushing	1
● 23	Ball Bearing	1	61	Reverse Valve Knob	1
★ 24	Rear End Plate Assembly (incl.23)	1	62	O-Ring	1
26	Rotor Blade	6	● 63	Heli-Coil	9
27	Rotor	1	TK	Tune-Up Kit { incl.2A.5.6.9.16.18.19.22.23.26 (6) .31.32.34.42.48.49.62 }	
28	Cylinder	1			

★ Must be Purchased in Assembly Set

● Recommended not to be purchased alone due to assembly difficulty