

2 IN 1 1/4" HEX.& 1/2" SQ. DR. IMPACT WRENCH&SCREWDRIVER

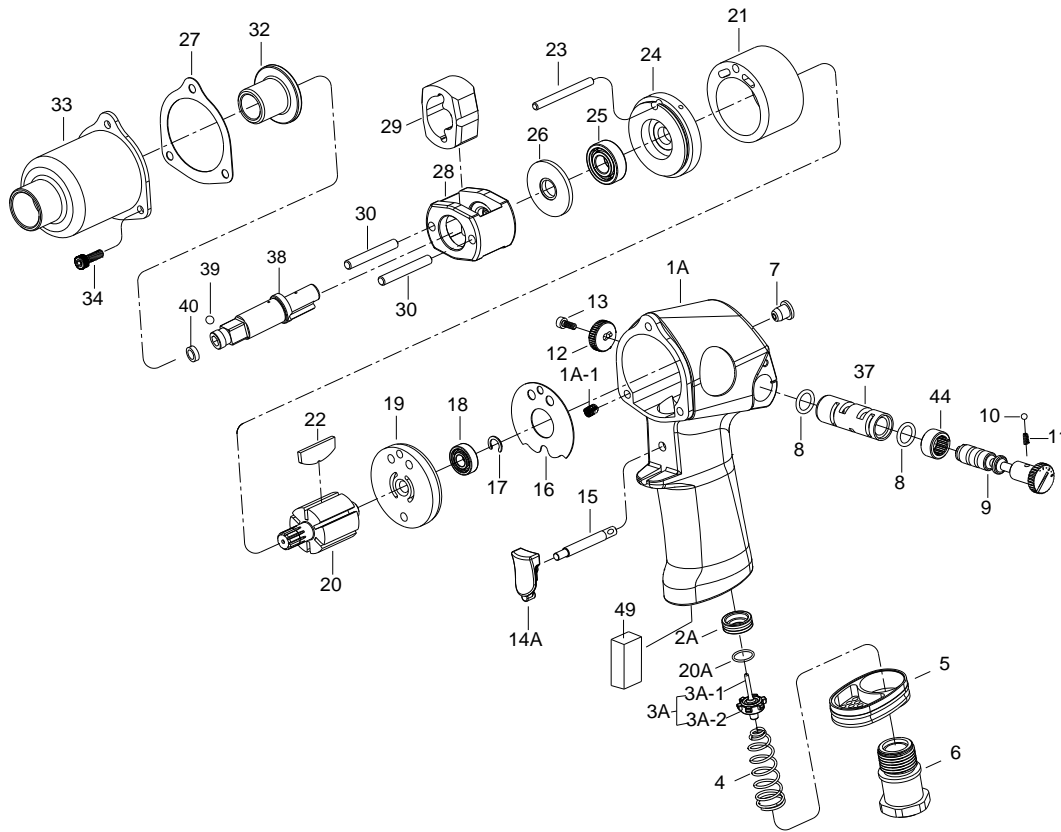

411JHS

INDEX NO.	DESCRIPTION	REQ'D NO.	INDEX NO.	DESCRIPTION	REQ'D NO.
★ 1A	Housing Assembly { incl.1A-1 (3).7.37.44 }	1	20	Rotor	1
● 1A-1	Helix-Coil	3	20A	O-Ring	1
2A	Throttle Valve Seat	1	21	Cylinder	1
★ 3A	Throttle Valve Assembly (incl.3A-1.3A-2)	1	22	Rotor Blade	6
● 3A-1	Throttle Valve Pin	1	23	Cylinder Dowel	1
● 3A-2	Throttle Valve	1	24	Front End Plate	1
4	Throttle Valve Spring	1	25	Ball Bearing	1
5	Exhaust Deflector	1	26	Washer	1
6	Air Inlet	1	27	Gasket	1
● 7	Grease Fitting	1	28	Hammer Frame	1
8	O-Ring	2	29	Hammer	1
9	Reverse Valve	1	30	Hammer Pin	2
10	Steel Ball	1	32	Bushing	1
11	Ball Spring	1	33	Hammer Case	1
12	Reverse Valve Knob	1	34	Screw	3
13	Knob Screw	1	● 37	Reverse Valve Bushing	1
★ 14A	Trigger Assembly (incl.15)	1	★ 38	Standard Anvil Assembly (incl.39.40)	1
● 15	Trigger Pin	1	● 39	Steel Ball	1
16	Gasket	1	● 40	Socket Retainer	1
17	Retainer	1	● 44	Reverse Valve Bushing Gear	1
18	Ball Bearing	1	49	Muffler Element	1
19	Rear End Plate	1	TK	Tune-Up Kit { 4.8 (2).10.11.16.17.18.20A.22 (6).25.39.40 }	

★ Must be Purchased in Assembly Set

● Recommended not to be purchased alone due to assembly difficulty

PA1-00411-4

20110426R2