

# 1/2" SQ. DR.SUPER DUTY IMPACT WRENCH

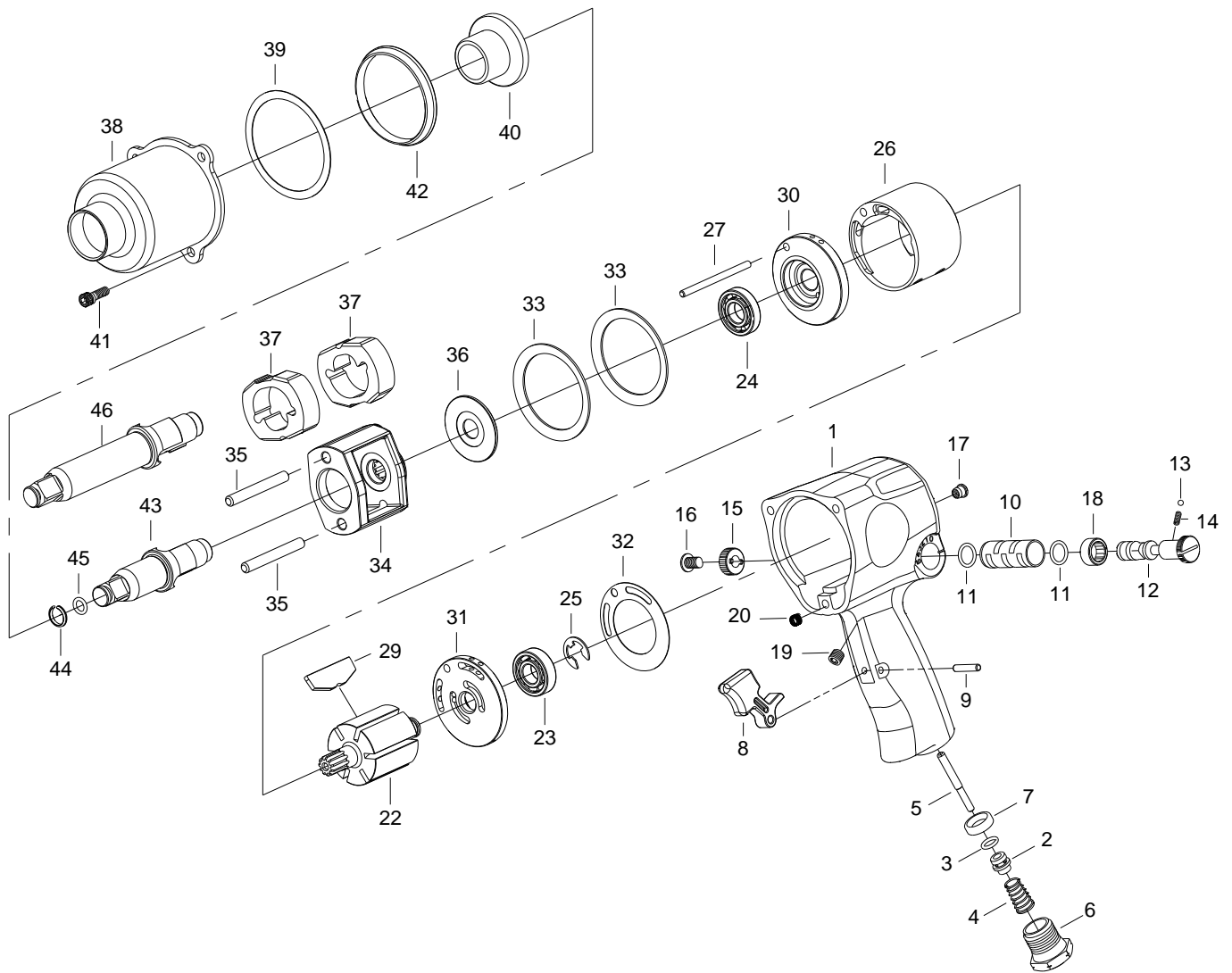

## 853/853-2

INDEX NO.	DESCRIPTION	REQ'D NO.	INDEX NO.	DESCRIPTION	REQ'D NO.
★ 1	Housing Assembly ( incl.7.10.17.18.19.20 )	1	25	Retainer	1
2	Throttle Valve	1	26	Cylinder	1
3	O-Ring	1	27	Cylinder Dowel	1
4	Spring	1	29	Rotor Blade	6
5	Throttle Valve Plunger	1	30	Front End Plate	1
6	Air Inlet	1	31	Rear End Plate	1
● 7	Throttle Valve Seat	1	32	Gasket	1
8	Trigger	1	33	Motor Clamp Washer	2
9	Trigger Pin	1	34	Hammer Frame	1
● 10	Reverse Valve Bushing	1	35	Hammer Pin	2
11	O-Ring	2	36	Washer	1
12	Reverse Valve	1	37	Hammer	2
13	Steel Ball	1	38	Hammer Case	1
14	Spring	1	39	Gasket	1
15	Reverse Valve Knob	1	40	Bushing	1
16	Screw	1	41	Screw	3
● 17	Grease Fitting	1	42	Separator	1
● 18	Reverse Valve Bushing Gear	1	43	Standard Anvil ( for KI-853 )	1
● 19	Set Screw	1	44	Socket Retainer	1
● 20	Heli-Coil	3	45	O-Ring	1
22	Rotor	1	46	2" Extended Anvil ( for KI-853-2 )	1
23	Ball Bearing	1	TK	Tune-up Kit { incl.3.4.11 ( 2 ).13.14.23.24.25.29 ( 6 ).32	
24	Ball Bearing	1		39.44.45 }	

★ Must be Purchased in Assembly Set

● Recommended not to be purchased alone due to assembly difficulty

20140318R2