

# 3/8" HEAVY DUTY REVERSIBLE AIR ANGLE DRILL

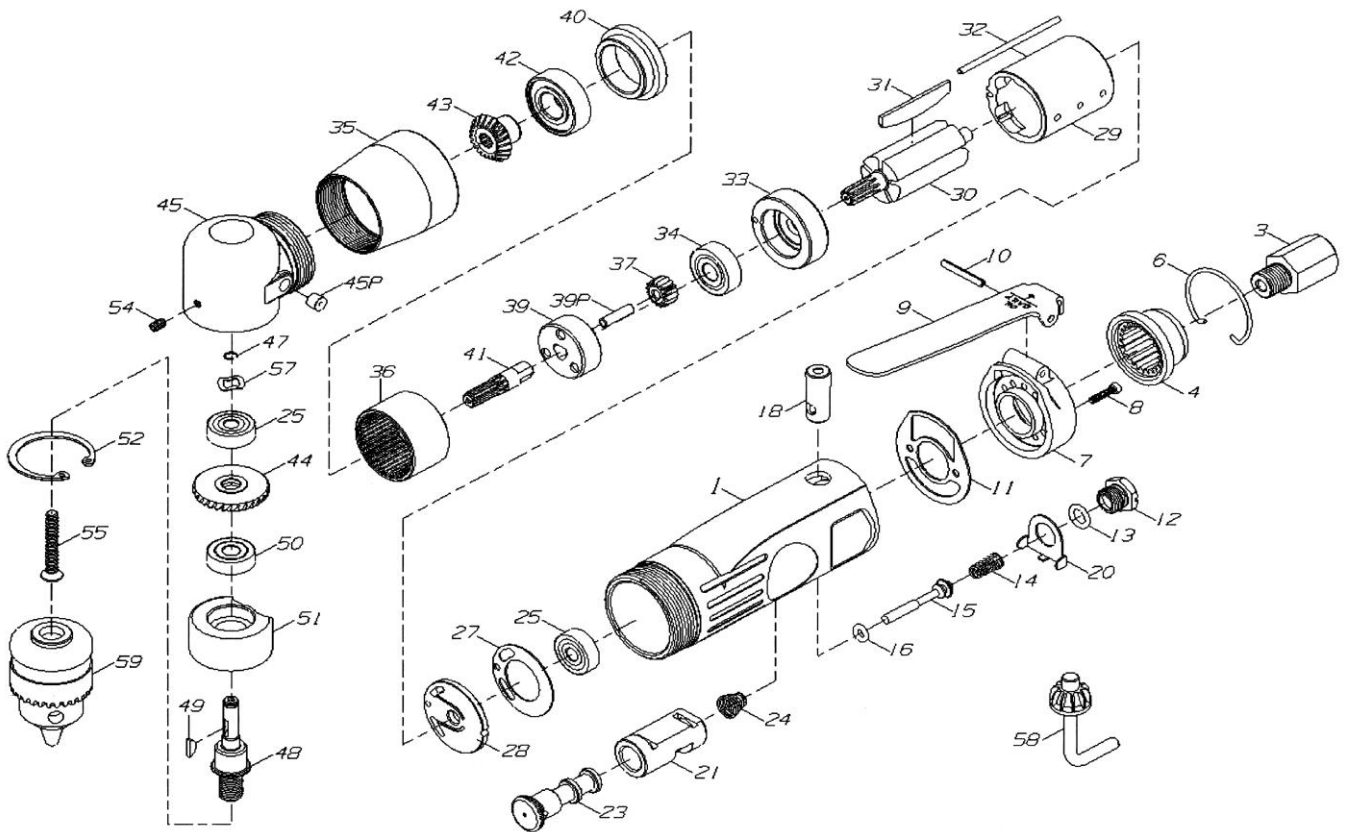

867

INDEX NO.	DESCRIPTION	REQ'D NO.	INDEX NO.	DESCRIPTION	REQ'D NO.
01	Motor Housing	1	32	Motor Pin	1
03	Inlet Bushing	1	33	Front End Plate	1
04	Deflector	1	34	Ball Bearing	1
06	Stop Ring	1	35	Lock Ring	1
07	Housing Cap	1	36	Internal Gear	1
08	Screw	2	37	Planet Gear	3
09	Lever	1	39	Cage	1
	Safety Lever(Optional)		39P	Pin	3
10	Pin	1	40	Spacer	1
11	Housing Gasket	1	41	Gear Spindle	1
12	Valve Screw	1	42	Ball Bearing	1
13	O-Ring	1	43	Pinion	1
14	Valve Spring	1	44	Gear	1
15	Throttle Valve	1	45	Angle Housing(inc.#45P)	1
16	O-Ring	1	45P	Ball Cap	1
18	Valve Bushing	1	47	Retainer Ring	1
20	Retainer	1	48	Spindle	1
21	Bushing	1	49	Key	1
23	Reverse Valve	1	50	Ball Bearing	1
24	Reverse Spring	1	51	Bearing Case	1
25	Ball Bearing	2	52	Retainer Ring	1
27	Motor Gasket	1	54	Set Screw	1
28	Rear End Plate	1	55	Screw	1
29	Cylinder (P.M.)	1	57	Wave Washer	1
	Cylinder (Steel)(Option)		58	Chuck Key	1
30	Rotor	1	59	3/8" Chuck	1
31	Rotor Blade	5		3/8" Keyless Chuck	