

# Operation, Maintenance and Parts Manual for 4211-V (7.8~4.8) Air Hydraulic Riveter

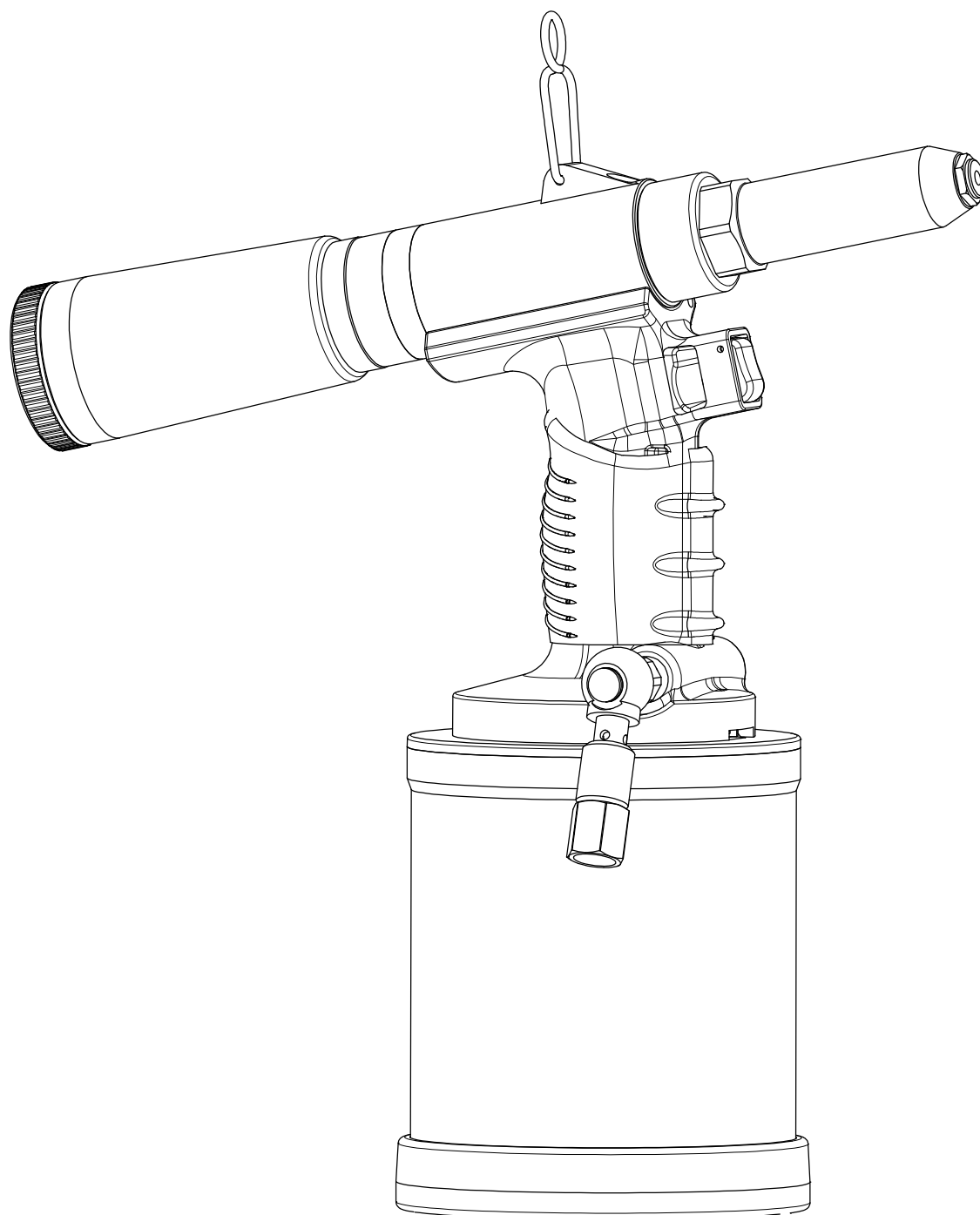

## Contents

<i>TOOL SPECIFICATION</i> .....	2
<i>GENERAL DESCRIPTION</i> .....	3
<i>SAFETY INSTRUCTIONS</i> .....	4
<i>OPERATION INSTRUCTIONS</i> .....	5
<i>MAINTENANCE</i> .....	7
<i>TROUBLESHOOTING</i> .....	8
<i>PART LIST FOR 4211-V TOOL</i> .....	9
<i>OPERATION GUIDES</i> · <i>Operational Method</i> .....	13-14

## List of Figures

<i>FIG 1 4211-V RIVET-PULL TOOL</i> .....	3
<i>FIG 2 DETAIL ILLUSTRATION OF CHANGE THE NOSEPIECE, JAW, AND JAW PUSHER.</i> .....	4
<i>FIG 3 DETAIL ILLUSTRATION OF SUCTION ADJUSTMENT AND CLEAN UP THE SAFETY CAP.</i> .....	5
<i>FIG 4 ADD OIL.</i> .....	7
<i>FIG 5 COMPONENTS OF 4211-V RIVET-PULL TOOL</i> .....	9

# TOOL SPECIFICATIONS

## Technical Data

Model Of Tool.....	4211-V
Dimensions.....	12" X 12.79" X 4.99"
(Length X Height X Width)	(305mm X 325mm X126.8mm)
Weight.....	4.8 <i>lbs</i> [2.18 Kgs]
Air Inlet.....	1/4" NPT
Recommended Operating Pressure.....	70 to 95 <i>psi</i> [4.9 to 6.67 kg/cm2]
Air Consumption.....	4CFM
Pulling Load.....	5000lbs(2270kg)
Max. Stroke.....	1.023 <i>in</i> [26 mm]
Rivet Nut Size.....	5/16",1/4",7/32", 3/16"

### DANGER

Indicates an imminently hazardous situation which, if not avoided, will result in death or serious injury.

### WARNING

Indicates a potentially hazardous situation which, if not avoided, will result in death or serious injury.

### NOTE

Alerts the operator to useful information.

## GENERAL DESCRIPTION

The 4211-V Rivet-Pull Tool illustrated in Fig. 1 with its pneumatic hydraulic system provides an efficient, lightweight, powerful, and quiet tool for rivet nut installation. It is designed to provide long life and trouble free services.

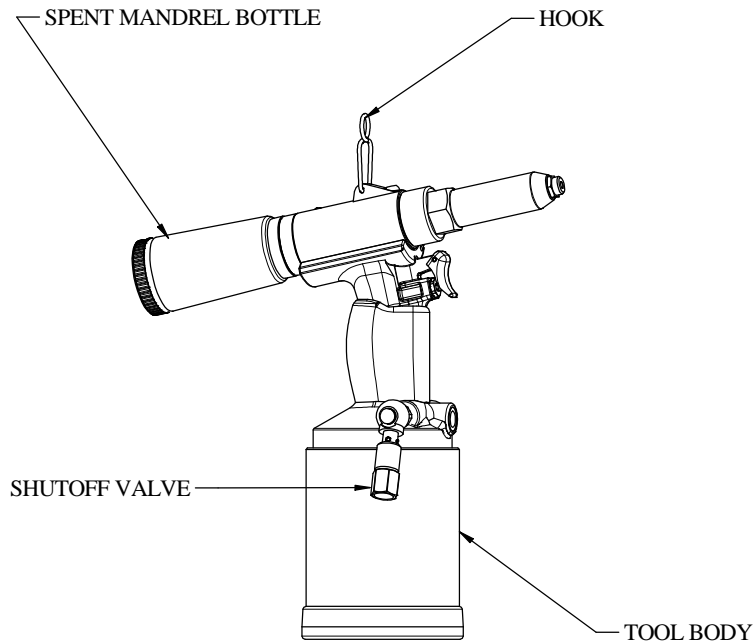

Fig. 1 4211-V Rivet-Pull Tool

## FEATURES

- **Heavy-duty use.**
- **Lightweight rivet-pull tool.**
- **High efficient, powerful and quiet installation tool.**
- **Easy maintenance and operation.**

# SAFETY INSTRUCTIONS

## DANGER



- Read this manual and understand all safety instructions before operating the tool. If you have any questions, please contact our authorized representatives.
- Any other use is prohibited.
- Be sure all hoses and fittings are the correct size and are tightly secured.
- Keep work area clean, uncluttered, ventilated and illuminated.



- Never allow the use of flammable gases (oxygen) as a power source for the tool. Use filtered, lubricated, and regulated compressed air only.



- Never use gasoline or other flammable liquids to clean the tool. Vapors in the tool can be ignited by a spark and cause the tool to explode.



- Do not exceed maximum permissible operating pressure of the tool (110 psig or 7.6 bars).



- Disconnect the tool from air supply before servicing, adjusting, and during non-operation.



## WARNING

- At the workplace, always wear protective equipment such as Z87.1 safety glasses, hearing protection and head protection.



- Repairing and cleaning operations must be done when the tool is not fed.

- This tool is not designed for working in explosive environments.

- That unsuitable postures may not allow counteracting of normal or unexpected movement of this tool.

- Always turn off the air supply and disconnect the air supply hose before installing, removing or adjusting any accessory on this tool.

- If this tool is fixed to suspension device, make sure that the fixation is secure.

- It could cause crushing if nose equipment is not fitted.

- Check that the protection against ejection of fastener and stem is in place and is operative.

- This tool is possible forcible ejection of installation mandrels from the front of this tool.

- Be aware of the whipping compressed air hose.

- Release the trigger in case of a failure of energy supply.

# OPERATION INSTRUCTIONS

A. To prepare 4211-V

1. Following the steps below to install the desired nosepiece:

- a. Loosen and remove the nosepiece (Index 37 in Figs. 2 & 5), then set up the desired nosepiece (Index 37~37-3 in Figs. 2 & 5) on frame head as shown in Fig. 2;
- b. Then assemble the frame head and lock it with the corresponding ring nut loosen before.

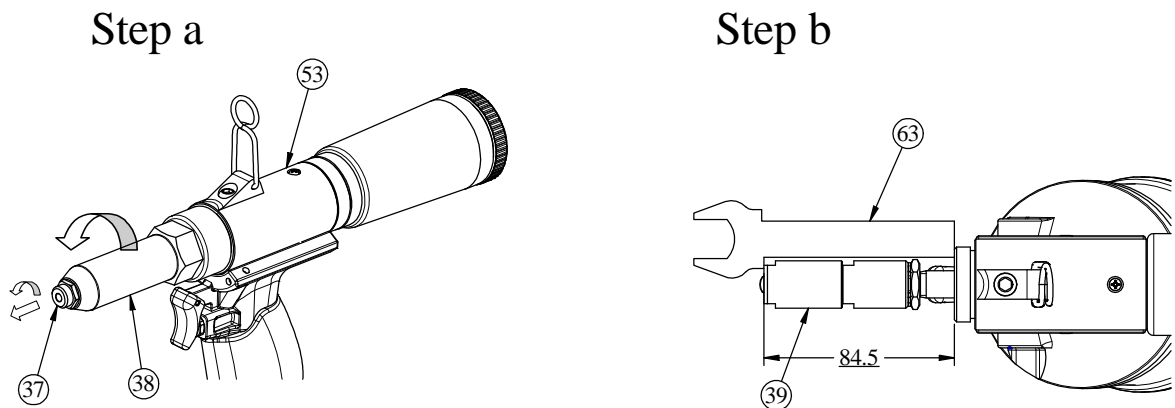

Fig. 2 Detail illustration of change the nosepiece, jaw, and jaw pusher.

B. To operate 4211-V

- a. Open the shutoff valve, let the air enter the 4211-V rivet-pull tool.
  - ※ When use the 4211-V rivet-pull tool, the shutoff valve must be in the open state, otherwise there was no suction to inhale the rivet.
- b. Is it make suction switch is it control suction to come, anticlockwise direction it is heavy for suction to, the clockwise suction is diminished to fasten, can close the suction(Index 48 in Figs.3 & 5)
- c. Put in the matching rivet into the nosepiece, then pressing the trigger to pulls and discharge the rivet's rod into the spent mandrel bottle.
- d. When the spent mandrel bottle is filled with rivet's rod, then pulls out the mandrel bottle adapter (Index 61 in Figs.3 & 5) and pours out all of them.
- e. After clean all of junk, plug the mandrel bottle adapter into the spent mandrel bottle. Then follow the normal operating step to use it.

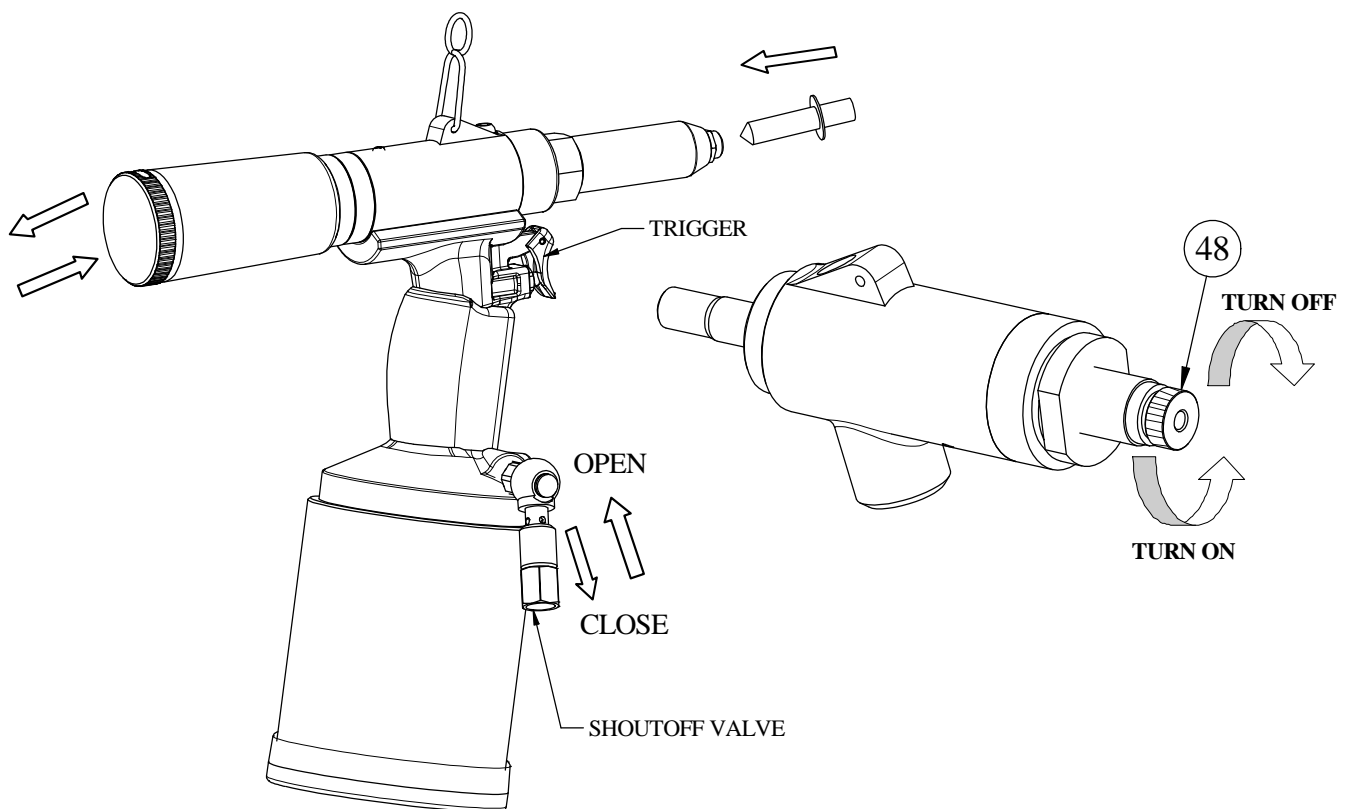

Fig. 3 Detail illustration of open the suction and clean up the spent mandrel bottle.

**NOTE**

**when to pull the Ø4.8" rivets, It is greatest to transfer the suction switch**

# Maintenance

The maintenance required when the tool of 4211-V pulling strength were become lower, it is only necessary to add ISO VG46 oil or similar grade oil into the hydraulic system., the operation steps as below:

1. Unscrew and remove the front head (Index 38) Turn the tool upside down and well fixed, then use spanner remove No.1 parts.

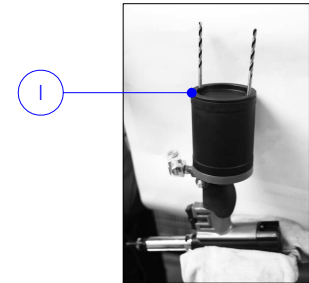

2. Remove No.7 parts.

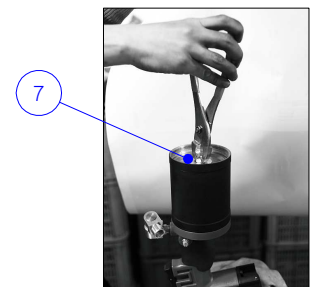

3. Take the oil pot fill the oil up to top of No.16 parts, installed No.7 parts press up and down twice ,get the No.7 out, refill the oil reach the top of No.16.

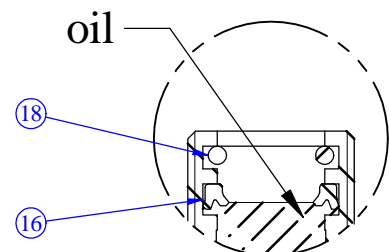

4. Lubricate all connected O Ring area by grease, No.7 insert it.

5. . Screw on No.1 ,Then assemble the jaw housing and adjust it's length to match the spanner gauge and fix front head (Index 38)

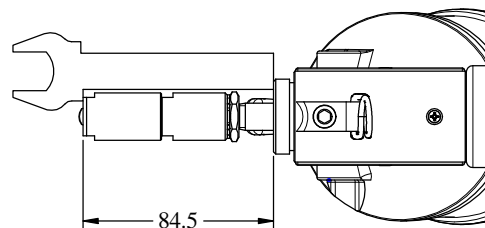
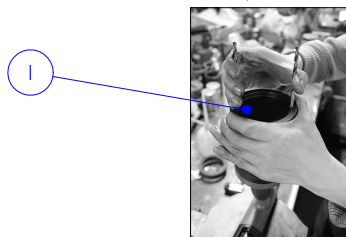

Fig. 4 ADD OIL.



## TROUBLESHOOTING

Stop using the tool immediately if any of the following problems occur. Any repairs or replacements must be done by a qualified person or an authorized service center only.

PROBLEM	CAUSE	REMEDY
Rivet jammed	Wrong size rivet.	The different rivets need to change the compared nosepiece, jaw and jaw pusher. Please read the operation instruction, and check the rivet's size again, see Fig. 2
	Had some filings jam in the 39 part's internal.	Using the adjustable wrench or 62 part to dismantle the part 38, then using the 19mm spanner to dismantle the part 39. Use hairbrush and airbrush to clean out filing; then smear the oil on them. Lock back the 38 and 39 part, see the Fig. 2d.
	Had some filings stick on the 37 part's top.	When you pull the aluminum rivet, it is happened frequently. Use the sharp thing to cancel the stuck filing.
No suction	The shutoff valve was not open.	Please see the Fig-3.
Air leaking.	Damaged o-rings.	O-rings need to be replaced.
	Loose screws.	Screws need to be tightened.
Frame Head(38) out of order.	Parts (16) (18) are damaged or deformed.	New parts (16)(18) need to be replaced.
Tool runs slow or has loss of power.	Air feeding tube loose.	Re-install and tighten the tube.
	Exhaust port in cap is blocked.	Exhaust port(20) needs to be cleaned.
	Operating pressure is too low.	Increase the operating pressure to 85-95psi.

## ADVICE

1. Clean out the parts 38~42, and smear the oil in every 500 times' operated.
2. Advise you to change the parts 40~43 in every 20000 times, when to pull the 1/4" (Ø6.4)stainless steel rivets.
3. The part 59(spent mandrel bottle) need to clean out, when it filled 35 rivets' residues.

## Part List for 4211-V Tool

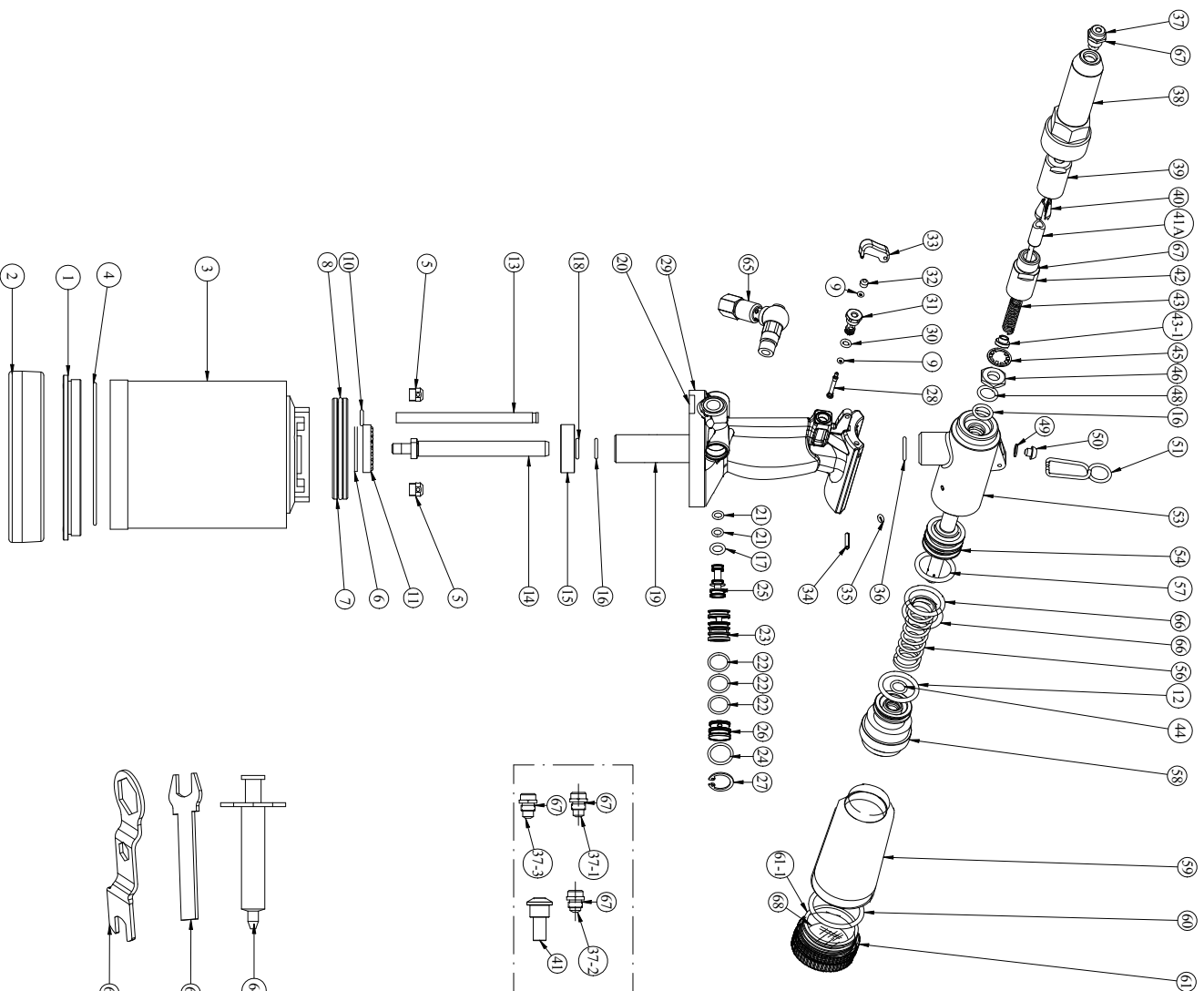

Part No.	Part Nam	Qty
01	Cylinder Cap	1
02	Rubber Bottom	1
03	Air Cylinder Body	1
04	O-Ring	1
05	Valve	2
06	Washer	1
07	Air Piston	1
08	O-Ring	1
09	O-Ring	2
10	O-Ring	1
11	Crash Washer	1
12	O-Ring	1
13	Tube	1
14	Rod	1
15	Stem Nut	1
16	Seal	2
17	O-Ring	1
18	Wear Ring	1
19	Stem	1
20	Muffler	1
21	O-Ring	2
22	O-Ring	3
23	Cage	1
24	O-Ring	1
25	Valve	1
26	Valve Cap	1
27	Retaining Ring	1
28	Valve Piston	1
29	Handle Body	1
30	O-Ring	1
31	Trigger Insert	1
32	Trigger Head	1
33	Trigger	1
34	Spring Pin	1
35	O-Ring	1
36	O-Ring	1

Part No.	Part Nam	Qty
37	Nosepiece (1/4"Ø6.4	1
37-1	Nosepiece (7/32"Ø5.6	1
37-2	Nosepiece (3/16"Ø4.8	1
37-3	Nosepiece (5/16"Ø7.8	1
38	Frame Head	1
39	Jaw Housing	1
40	Jaw	3
41	Jaw Pusher For (5/16" Max. Mandrel Diameter 4.5mm)	1
41A	Jaw Pusher For (1/4" 7/32" 3/16")	1
42	Jaw Housing Coupler	1
43	Spring	1
43-1	Spring Collar	1
44	O-Ring	1
45	Case Washer	1
46	Case Lock Nut	1
48	O-Ring	1
49	Oil Seal Washer	1
50	Hexagon Socket Screw	1
51	Hook	1
53	Oil Cylinder Body	1
54	Piston Rod II	1
56	Spring	1
57	Seal	1
58	Frame Cap Nut	1
59	Spent Mandrel Bottle	1
60	O-Ring	1
61	Mandrel Bottle Adapter	1
61-1	Silencer	1
62	Spanner	1
63	Spanner Gauge	1
64	Oil Can	1
65	Shout off Valve	1
66	O-Ring	2
67	O-Ring	5
68	Cushion	1

0000.00.00  
2018.05.18

Fig. 5 of 4211-V Tool.