

# HEAVY DUTY VIBRATION-DAMPED AIR PITTSBURGH LOCK HAMMER

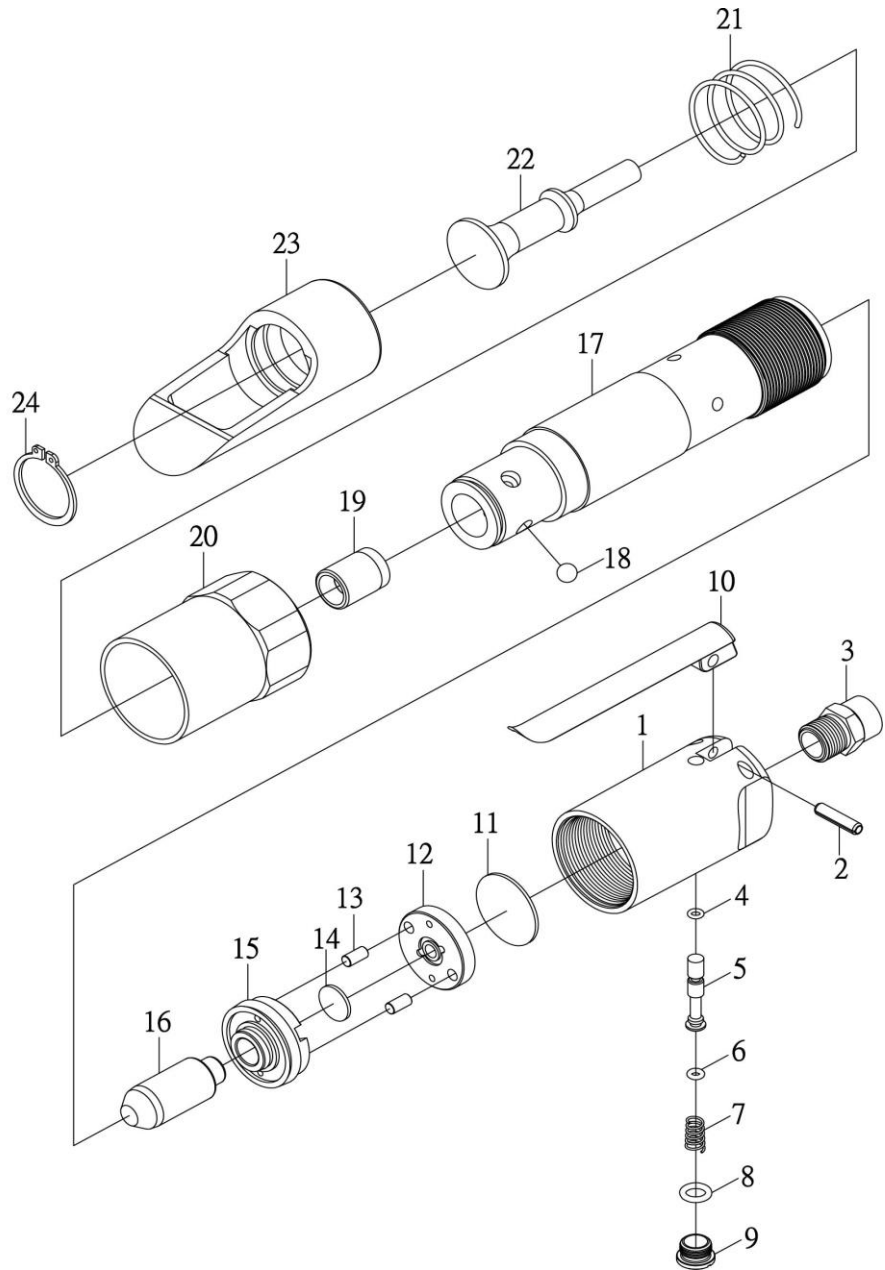
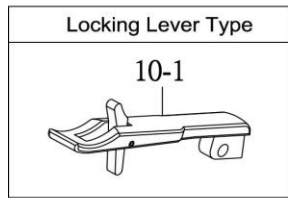

4704-PH

INDEX NO.	DESCRIPTION	REQ'D NO.	INDEX NO.	DESCRIPTION	REQ'D NO.
01	Handle	1	13	Valve Block Dowel Pin	2
02	Spring Pin	1	14	Valve Cycling	1
03	Air Inlet Bushing	1	15	Upper Main Valve	1
04	O-Ring	1	16	Piston (Long)	1
05	Valve-Throttle	1	17	Cylinder (Long)	1
06	O-Ring	1	18	Ball-Steel	4
07	Spring-Valve	1	19	Chisel-Bushing	1
08	O-Ring	1	20	Exhaust Deflector (Long)	1
09	Throttle Valve Cap	1	21	Spring-Compression	1
10	Throttle Lever	1	22	Anvil	1
10-1	Locking Lever (Option)		23	Guide	1
11	Alignment Shim	1	24	Snap Ring	1
12	Lower Main Valve	1			

0000.00.00

2014.07.18