

HEAVY DUTY AIR FLUX CHIPPER

氣動熔接劑鑿平機

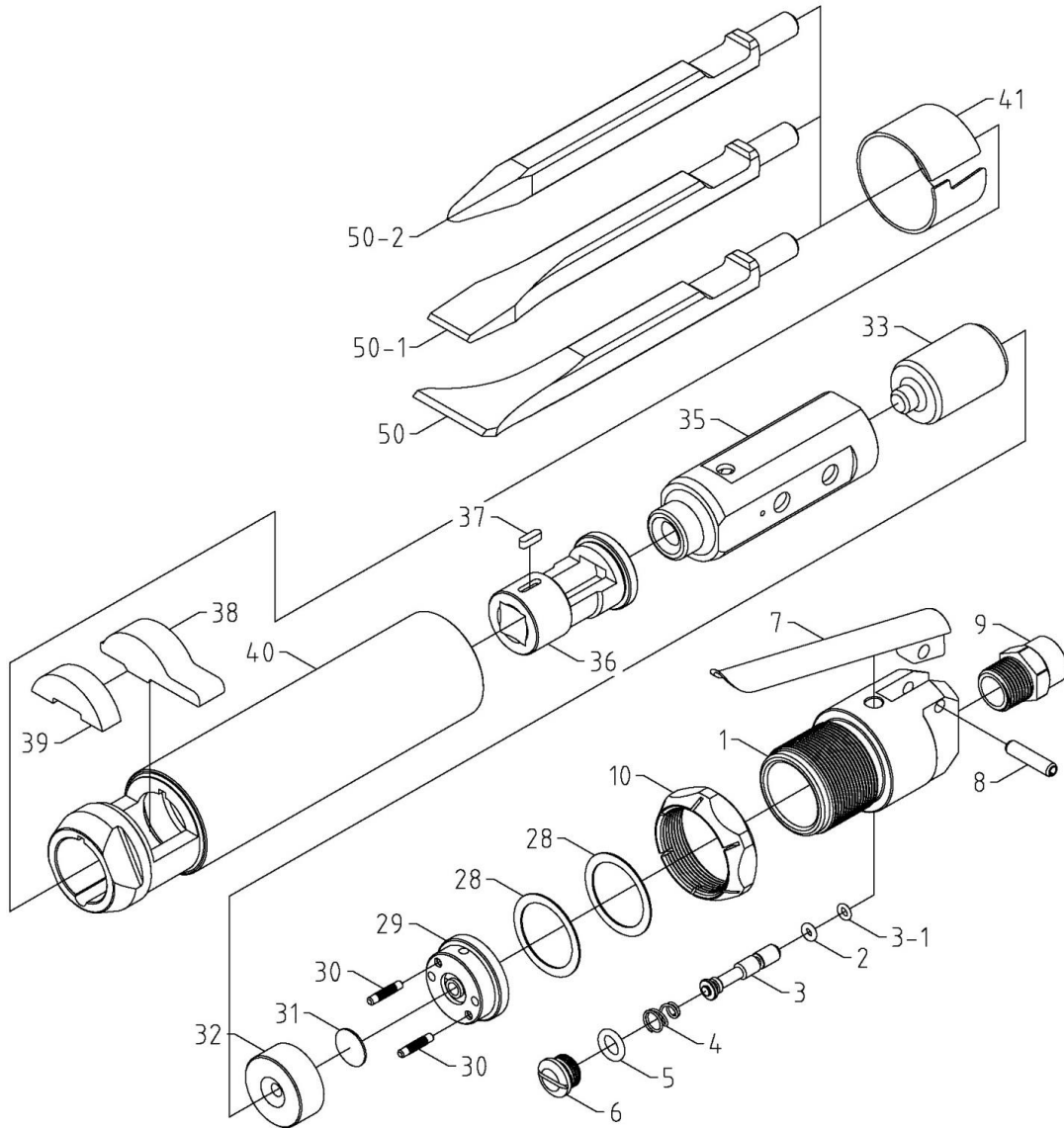

4719

INDEX NO.	DESCRIPTION	中文名稱	REQ'D NO.	INDEX NO.	DESCRIPTION	中文名稱	REQ'D NO.
01	Backhead	進氣主體	1	31	Valve Disc	閥片	1
02	O-Ring	O型環	1	32	Low Valve Case	前閥座	1
03	Valve Stem	進氣頂桿	1	33	Piston	活塞	1
03-1	O-Ring	O型環	1	35	Piston Sleeve	氣缸	1
04	Valve Spring	彈簧	1	36	Nose	頭座	1
05	O-Ring	O型環	1	37	Key	鍵	1
06	Valve Cap	進氣閥帽	1	38	Retainer	保持器	1
07	Lever	壓板板機	1	39	Retainer Buffer	緩衝保持器	1
08	Spring Pin	板機固定銷	1	40	Barrel	氣缸套筒	1
09	Inlet Bushing	1/4"進氣口	1	41	Retainer Clip	固定夾	1
10	Lock Ring	連結螺帽	1	50	Chisel (Bent,35mm)	彎鑿(35mm)	1
28	Washer	主體墊片	2	50-1	Chisel (Flat,20mm) (Option)	扁鑿(20mm)(選擇)	1
29	Upper Valve Case	後閥座	1	50-2	Chisel (Moil Point) (Option)	尖鑿(選擇)	1
30	Dowel Pin	定位銷	2				

0000.00.00

2010.08.23 2019.07.12