

HEAVY DUTY AIR PITTSBURGH LOCK HAMMER

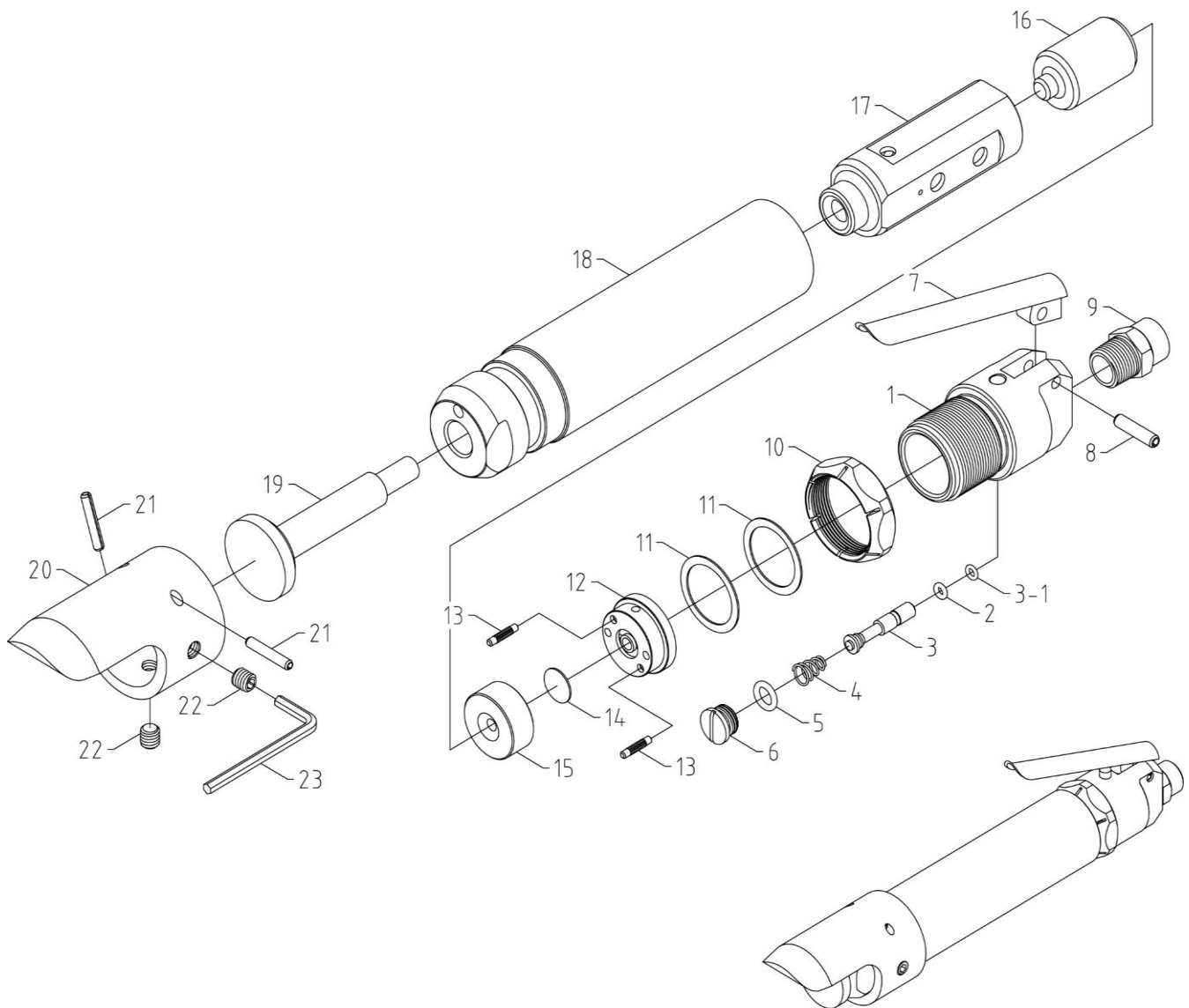

4719-PH

INDEX NO.	DESCRIPTION	REQ'D NO.	INDEX NO.	DESCRIPTION	REQ'D NO.
01	Backhead	1	12	Upper Valve Case	1
02	O-Ring	1	13	Dowel Pin	2
03	Valve Stem	1	14	Valve	1
03-1	O-Ring	1	15	Lower Valve Case	1
04	Valve Spring	1	16	Piston	1
05	O-Ring	1	17	Piston Sleeve	1
06	Valve Cap	1	18	Barrel	1
07	Lever	1	19	Driver	1
08	Spring Pin	1	20	Guide	1
09	Inlet Bushing (1/4")	1	21	Spring Pin	2
10	Lock Ring	1	22	Socket Set Screw (5/16")	2
11	Washer	2	23	Hex. Wrench (4mm)	1

0000.00.00

2011.05.25 2016.08.17