

# GENERAL DUTY AIR NEEDLE SCALER

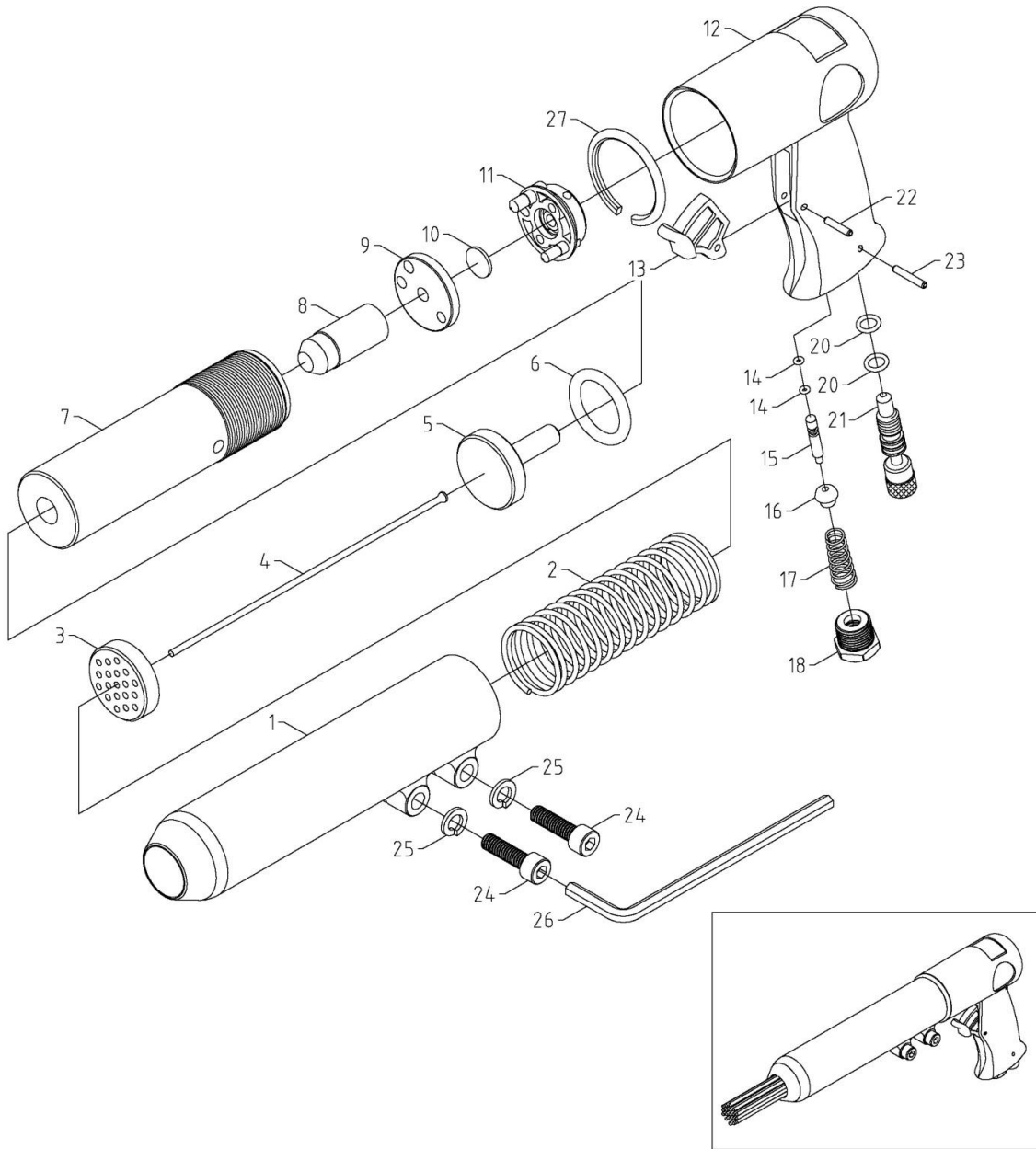

4789-X1N

INDEX NO.	DESCRIPTION	REQ'D NO.	INDEX NO.	DESCRIPTION	REQ'D NO.
01	Front Tube	1	14	O-Ring	2
02	Compression Spring	1	15	Valve Stem	1
03	Needle Holder (Ø 3×19 Holes)	1	16	Valve Ball	1
04	Needle (Ø 3×180L)	19	17	Valve Spring	1
05	Driver (R)	1	18	Inlet Bushing	1
06	O-Ring	1	20	O-Ring	2
07	Cylinder	1	21	Regulator	1
08	Piston	1	22	Spring Pin	1
09	Lower Valve Case	1	23	Spring Pin	1
10	Valve Disc	1	24	Cap Head Screw	2
11	Upper Valve Case	1	25	Spring Washer	2
12	Handle	1	26	Hex. Wrench (6mm)	1
13	Trigger	1	27	Washer	1

0000.00.00

2017.11.10 2019.07.01