

1/2" HEAVY DUTY AIR DRILL

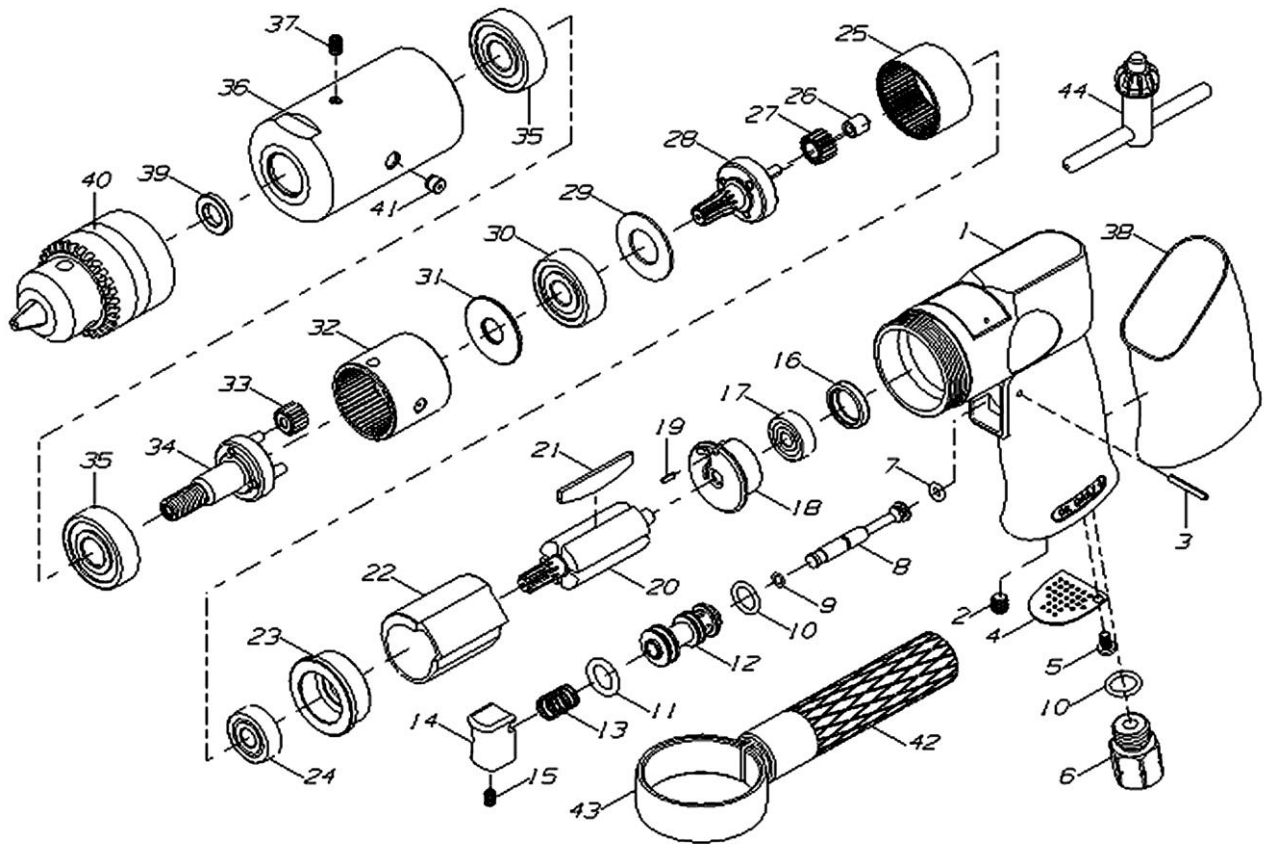

5409

INDEX NO.	DESCRIPTION	REQ'D NO.	INDEX NO.	DESCRIPTION	REQ'D NO.
01	Motor Housing	1	23	Front End Plate	1
02	Set Screw	1	24	Ball Bearing	1
03	Valve Pin	1	25	Ring Gear	1
04	Exhaust Deflector	1	26	Gear Bushing	3
05	Screw	1	27	Idler Gear	3
06	Inlet Bushing	1	28	Idler Gear Plate	1
07	O-Ring	1	29	Washer	1
08	Valve Stem	1	30	Ball Bearing	1
09	O-Ring	1	31	Spacer	1
10	O-Ring	2	32	Ring Gear	1
11	O-Ring	1	33	Idler Gear	3
12	Valve Bushing	1	34	Idler Gear Plate	1
13	Spring	1	35	Ball Bearing	2
14	Trigger	1	36	Clamp Nut	1
15	Set Screw	1	37	Set Screw	1
16	Cover	1	38	Housing Sleeve (Option)	1
17	Ball Bearing	1	39	Washer	1
18	Rear End Plate	1	40	1/2" Drill Chuck	1
19	Pin	1	41	Grease Cup	1
20	Rotor	1	42	Handle	1
21	Rotor Blade	4	43	Clamp Ring	1
22	Cylinder	1	44	1/2" Chuck Key	1

2008.01.01

2008.04.30