

HEAVY DUTY ORBITAL AIR ANGLE SANDER

氣動軌道彎頭砂光機

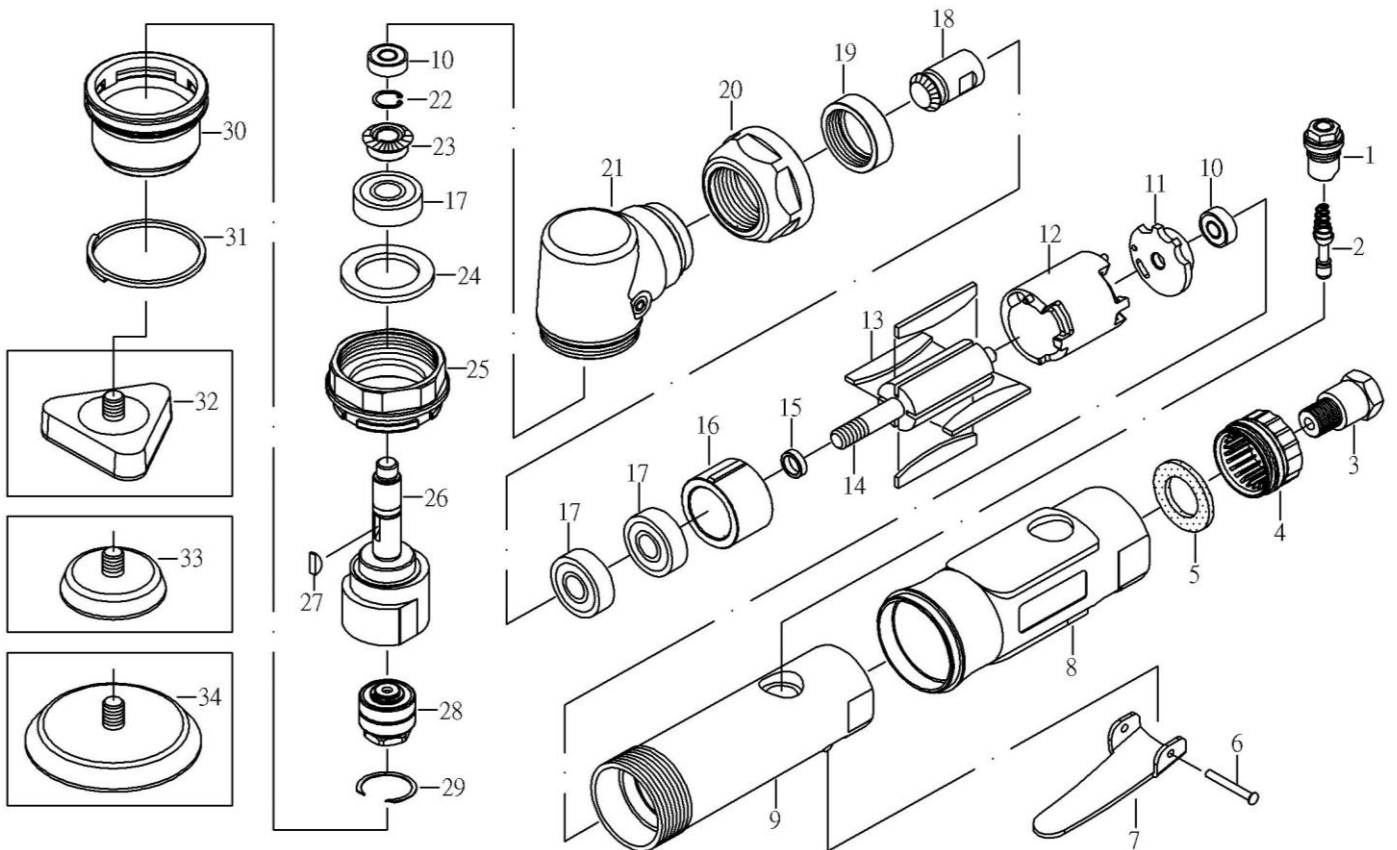

6511-A

INDEX NO.	DESCRIPTION	中文名稱	REQ'D NO.	INDEX NO.	DESCRIPTION	中文名稱	REQ'D NO.
01	Regulator Set	流量調節器組	1	18	Bevel Gear (10T)	傳動齒輪 (10T)	1
02	Valve Stem Set	進氣頂桿組	1	19	Nut	螺帽	1
03	Air Inlet	進氣口 (1/4")	1	20	Clamp Nut	鎖緊螺帽	1
04	Exhaust Sleeve Set	排氣罩組	1	21	Angle Housing Set	彎頭座	1
05	Cone Muffler	消音器	1	22	Snap Ring	扣環	1
06	Pin	板機固定銷	1	23	Bevel Gear (15T)	傘形齒輪 (15T)	1
07	Lever	板機	1	24	Washer	墊圈	1
	Locking Lever (Option)	安全板機		25	Clamp Nut	鎖緊螺帽	1
08	Protecting Rubber	膠套	1	26	Motor Shaft Balancer	曲軸	1
09	Housing	手柄	1	27	Key	鍵	1
10	Bearing	培林	2	28	Shaft Set	軸組	1
11	Rear Plate	後端板	1	29	Snap Ring	扣環	1
12	Cylinder Set	氣缸組	1	30	Rubber Cover	防塵蓋	1
13	Rotor Blade	葉片	4	31	Skirt Band	扣環	1
14	Rotor	轉子	1	32	1.5" Pad (Triangular)	1.5"墊 (三角)	1
15	Bearing Spacer	軸承墊圈	1	33	1.2" Pad (Round)	1.2"墊 (圓)	1
16	Front Plate	前端板	1	34	2" Pad (Round)	2"墊 (圓)	1
17	Bearing	培林	3				

0000.00.00

2018.12.05 2019.06.03