

# HEAVY DUTY ORBITAL AIR DUAL ACTION QUIET SANDER

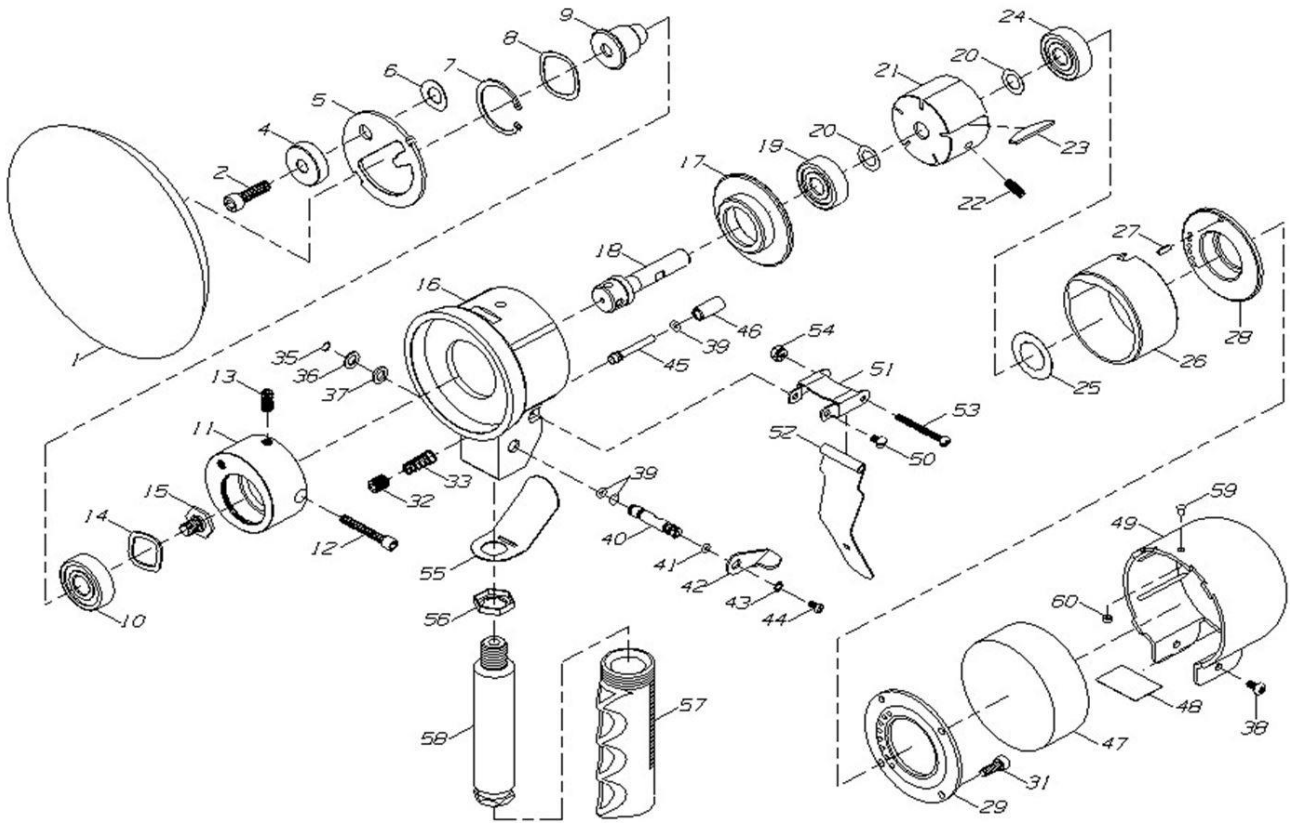

6611

INDEX NO.	DESCRIPTION	REQ'D NO.	INDEX NO.	DESCRIPTION	REQ'D NO.
01	5" Foam Pad (Yellow) (Option)	1	31	Rotor Screw	4
	6" Foam Pad (Black) (Standard)		32	Cap Screw	1
	6" Hook Surface (Black) (Option)		33	Throttle Spring	1
02	Cap Screw	1	35	Retaining Ring	1
04	Balance Nut	1	36	Plate Washer	1
05	Drive Cover	1	37	Rubber Washer	1
06	Wave Washer	1	38	Screw	2
07	Retaining Ring	1	39	O-Ring	3
08	Wave Washer	1	40	Regulator	1
09	Pad Mounting Shaft	1	41	O-Ring	1
10	Ball Bearing	1	42	Regulator Switch	1
11	Random Balance Body	1	43	Lock Washer	1
12	Socket Head Cap Screw	1	44	Screw	1
13	Fixing Screw	1	45	Push Rod	1
14	Wave Washer	1	46	Valve Body Bushing	1
15	Cap Screw	1	47	Muffler	1
16	Body	1	48	Muffler Element	1
17	Rear Plate	1	49	Motor Cover (Incl.59, 60)	1
18	Rotor Shaft	1	50	Screw	2
19	Ball Bearing	1	51	Lever Bracket	1
20	Shim	4	52	Throttle Lever	1
21	Rotor	1	53	Screw	1
22	Set Screw	1	54	Nut	1
23	Rotor Blade	5	55	Lever Booster	1
24	Ball Bearing	1	56	Lever Jam Nut	1
25	Bearing Shield	1	57	Plastic Handle	1
26	Cylinder	1	58	Hose Adapter	1
27	Pin	1	59	Rivet	1
28	Front Plate	1	60	Bushing	1
29	Rotor Fixing Cover	1			

0000.00.00

2018.12.04 2019.08.08