

# HEAVY DUTY AIR ANGLE GRINDER

## 氣動角向砂輪機

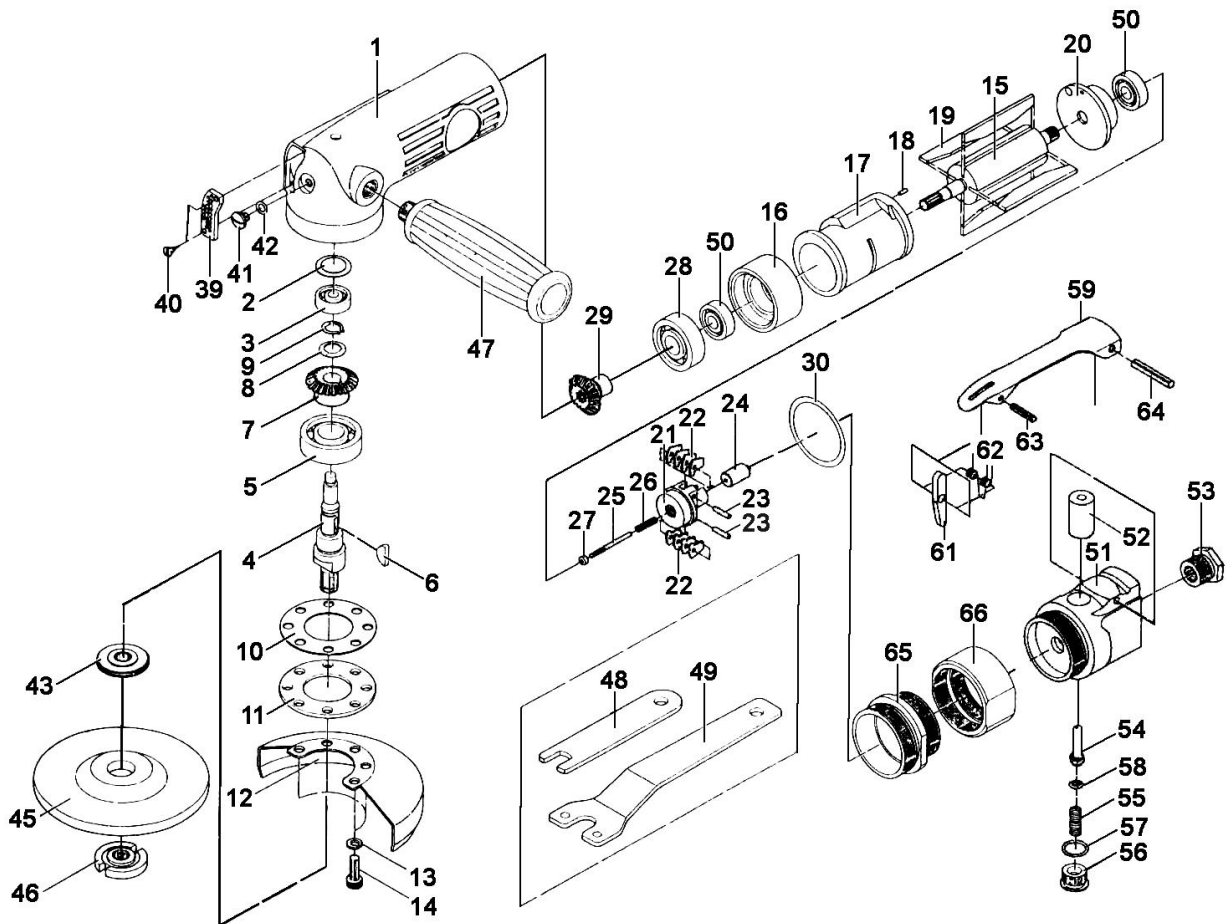

6801 / 6802

INDEX NO.	DESCRIPTION	中文名稱	REQ'D NO.	INDEX NO.	DESCRIPTION	中文名稱	REQ'D NO.
01	Motor Housing	手柄	1	29	Bevel Pinion	傳動齒輪	1
02	Seal Plate	封板	1	30	O-Ring	O型環	1
03	Bearing	滾珠軸承	1	39	Exhaust Deflector	排氣罩	1
04	Spindle	主軸	1	40	Screw	螺絲	2
05	Bearing	滾珠軸承	1	41	Plug	塞	1
06	Woodruff Key	鍵	1	42	O-Ring	O型環	1
07	Bevel Gear	傘形齒輪	1	43	Flange	凸緣	1
08	Wave Washer	墊圈	1	45	Grinding Wheel (Option)	砂輪(選擇)	1
09	Retaining Ring	扣環	1	46	Flange Nut	凸緣螺帽	1
10	Gasket	墊片	1	47	Handle	輔助握把	1
11	Retainer	保持器	1	48	Wrench (A)	扳手(A)	1
12	Center Wheel Guard (4") (For KI-6801)	4"砂輪護罩	1	49	Wrench (B)	扳手(B)	1
	Center Wheel Guard (5") (For KI-6802)	5"砂輪護罩		50	Bearing	滾珠軸承	2
13	Spring Washer	墊圈	5	51	Throttle Valve Housing	進氣主體	1
14	Hex. Socket Head Cap Bolt	螺絲	5	52	Valve Bushing	襯套	1
15	Rotor	轉子	1	53	Air Inlet	1/4"進氣口	1
16	Front End Plate	前端板	1	54	Valve Stem	進氣頂桿	1
17	Cylinder	氣缸	1	55	Valve Spring	彈簧	1
18	Spring Pin	固定銷	1	56	Plug	進氣閥帽	1
19	Rotor Blade	葉片	4	57	O-Ring	O型環	1
20	Rear End Plate	後端板	1	58	O-Ring	O型環	1
21	Governor	調節器	1	59	Throttle Lever	安全板機	1
22	Pendulum	擺動體	8	61	Throttle Lever Lock	安全板機鎖	1
23	Spring Pin	固定銷	2	62	Torsion Spring	彈簧	1
24	Plunger	柱塞	1	63	Spring Pin	固定銷	1
25	Adjust Screw	調整螺絲	1	64	Spring Pin	板機固定銷	1
26	Spring	彈簧	1	65	Lock Ring	連結螺帽	1
27	Adjust Nut	調整螺帽	1	66	Coupling	聯結器	1
28	Bearing	滾珠軸承	1				

0000.00.00

2009.03.11 2019.08.21