

1/2" SQ. DR. SUPER DUTY IMPACT WRENCH

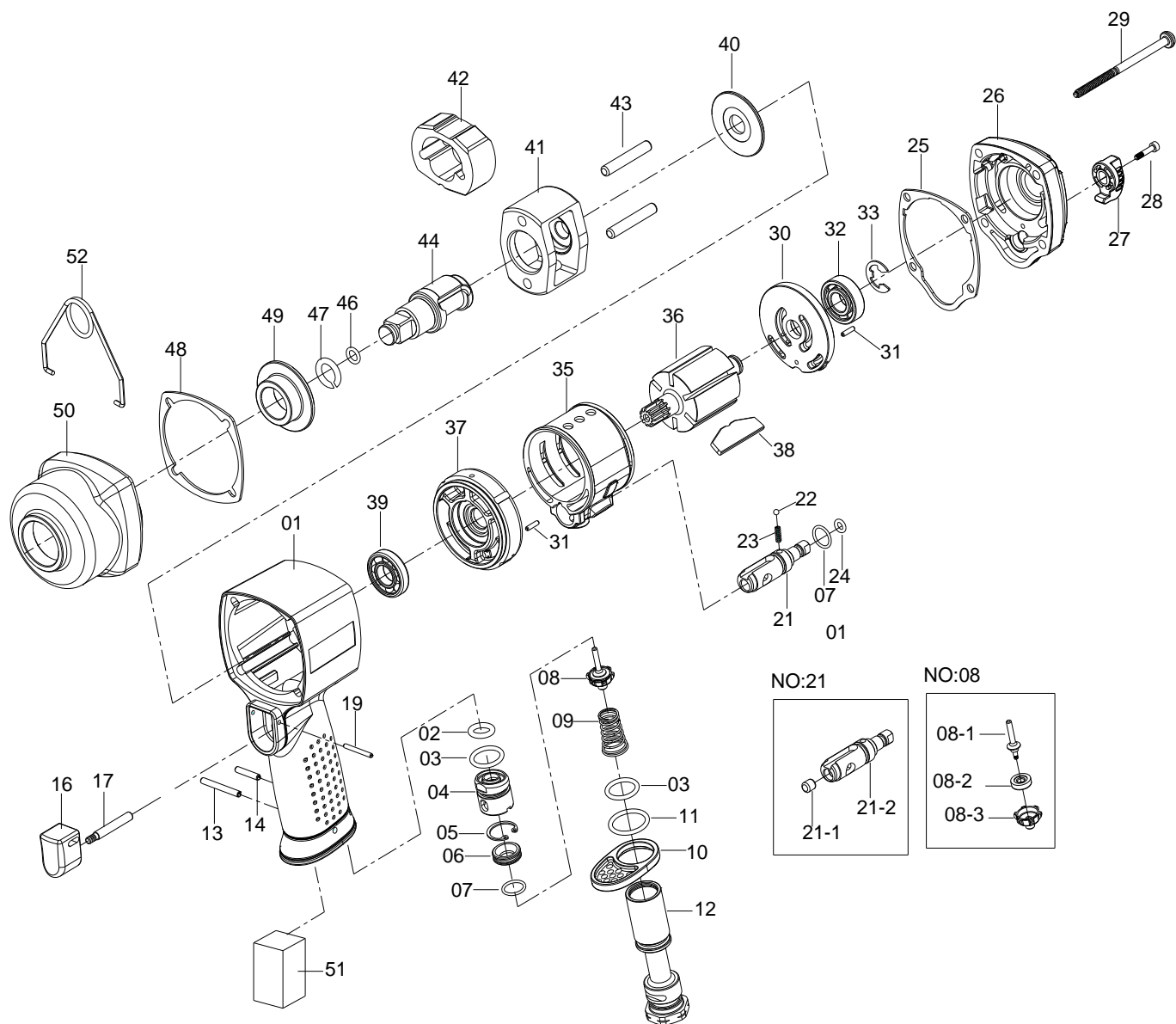

1450AT

INDEX NO.	DESCRIPTION	REQ'D NO.	INDEX NO.	DESCRIPTION	REQ'D NO.
1	Housing Assembly		26	Backhead	1
2	O-Ring	1	27	Reverse Valve Knob	1
3	O-Ring	2	28	Screw	1
4	Guide Tube	1	29	Screw	4
5	Retainer	1	30	Rear End Plate	1
6	Throttle Valve Seat	1	31	Spring Pin	2
7	O-Ring	2	32	Ball Bearing	1
★ 8	Throttle Valve Assembly (incl.8-1.8-2.8-3)	1	33	Retainer	1
● 8-1	Throttle Valve Pin	1	35	Cylinder	1
● 8-2	Rubber Seal	1	36	Rotor	1
● 8-3	Throttle Valve	1	37	Front End Plate	1
9	Spring	1	38	Rotor Blade	6
10	Exhaust Deflector	1	39	Ball Bearing	1
11	O-Ring	1	40	Washer	1
12	Air Inlet	1	41	Hammer Frame	1
13	Spring Pin	1	42	Hammer	1
14	Spring Pin	1	43	Hammer Pin	2
★ 16	Trigger Assembly (incl.17)	1	44	Standard Anvil	1
● 17	Trigger Pin	1	46	O-Ring	1
19	Spring Pin	1	47	Socket Retainer	1
★ 21	Reverse Valve Assembly (incl.21-1.21-2)	1	48	Gasket	1
● 21-1	Locking Plug	1	● 49	Bushing	1
● 21-2	Reverse Valve	1	★ 50	Hammer Case Assembly (incl.49)	1
22	Steel Ball	1	51	Muffler Element	1
23	Spring	1	52	Hanger	1
24	O-Ring	1	TK	Tune-Up Kit { 2.3 (2).7 (2).9.11.22.23.24.25.32.38 (6).39	
25	Gasket	1		46.47.48.51 }	

★ Must be Purchased in Assembly Set

● Recommended not to be purchased alone due to assembly difficulty