

1/2" SQ. DR. SUPER DUTY IMPACT WRENCH

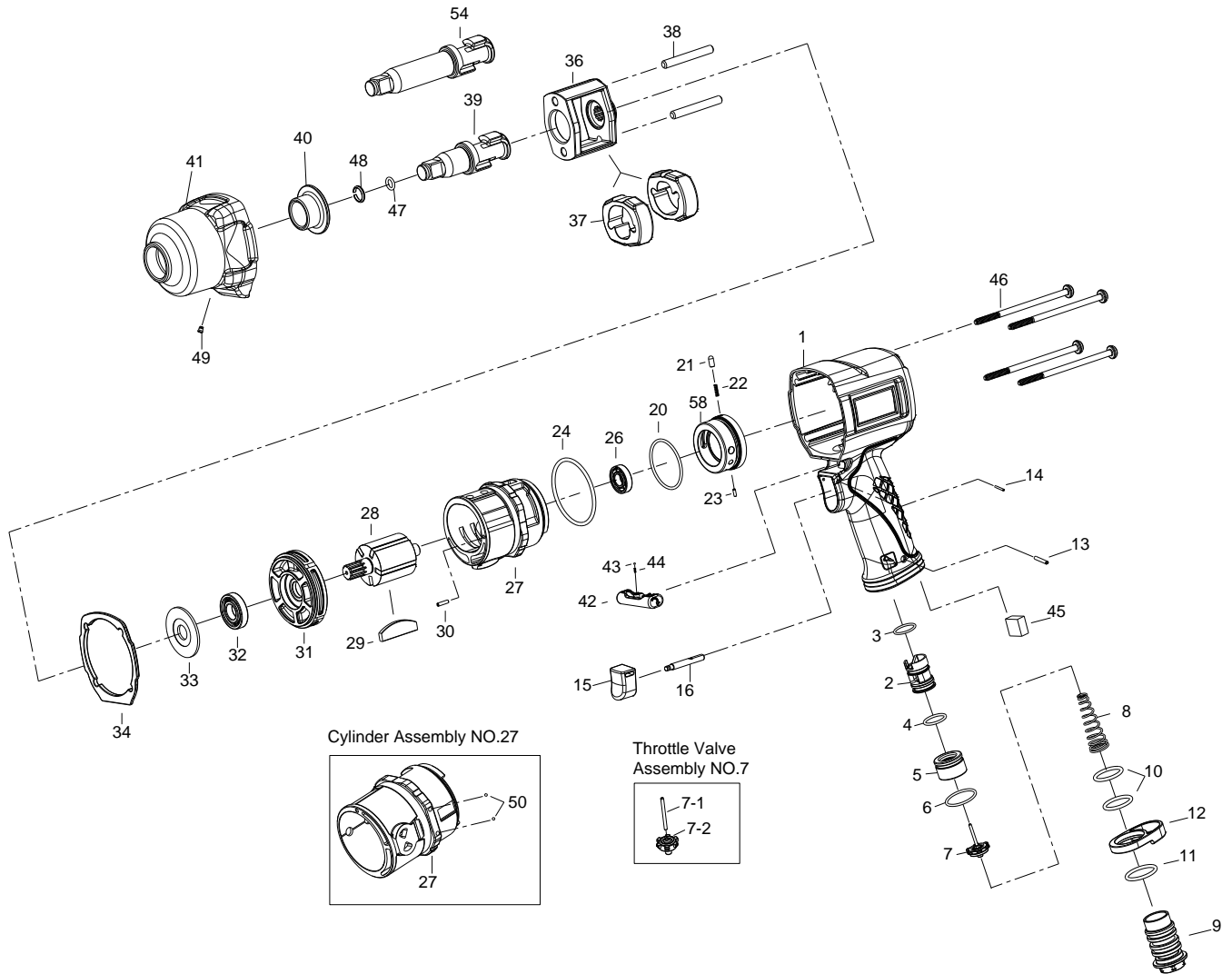

1481_1481-2

INDEX NO.	DESCRIPTION	REQ'D NO.	INDEX NO.	DESCRIPTION	REQ'D NO.
1	Motor Housing	1	28	Rotor	1
2	Reverse Valve	1	29	Rotor Blade	7
3	O-Ring	1	30	Rotor Spring Pin	1
4	O-Ring	1	31	Front End Plate	1
5	Throttle Valve Seat	1	32	Ball Bearing	1
6	O-Ring	1	33	Washer	1
★ 7	Throttle Valve Assembly (incl. 7-1,7-2)	1	34	Gasket	1
● 7-1	Throttle Valve Pin	1	36	Hammer Frame	1
● 7-2	Throttle Valve	1	37	Hammer	2
8	Spring	1	38	Hammer Pin	2
9	Air Inlet	1	39	Standard Anvil (for 1481)	1
10	O-Ring	2	● 40	Bushing	1
11	O-Ring	1	★ 41	Hammer Case Assembly (incl.40,49)	1
12	Exhaust Deflector	1	42	Reverse Knob	1
13	Spring Pin	1	43	Steel Ball	1
14	Spring Pin	1	44	Steel Ball Spring	1
★ 15	Trigger Assembly (incl.16)	1	45	Muffler Element	1
● 16	Trigger Pin	1	46	Screw	4
20	O-Ring	1	47	O-Ring	1
21	Pin	1	48	Socket Retainer	1
22	Spring	1	● 49	Grease Fitting	1
23	Spring Pin	1	● 50	Steel Ball	2
24	O-Ring	1	54	Extended Anvil (for 1481-2)	1
26	Ball Bearing	1	58	Reverse Valve Knob	1
★ 27	Cylinder Assembly { incl.50 (2) }	1	TK	Tune-Up Kit { incl.3.4.6.8.10 (2).11.20.22.24.29 (7).34.43.44.45.47.48 }	

★ Must be Purchased in Assembly Set

● Recommended not to be purchased alone due to assembly difficulty

20150127R2