

1/2" SQ. DR. SUPER DUTY AIR IMPACT WRENCH

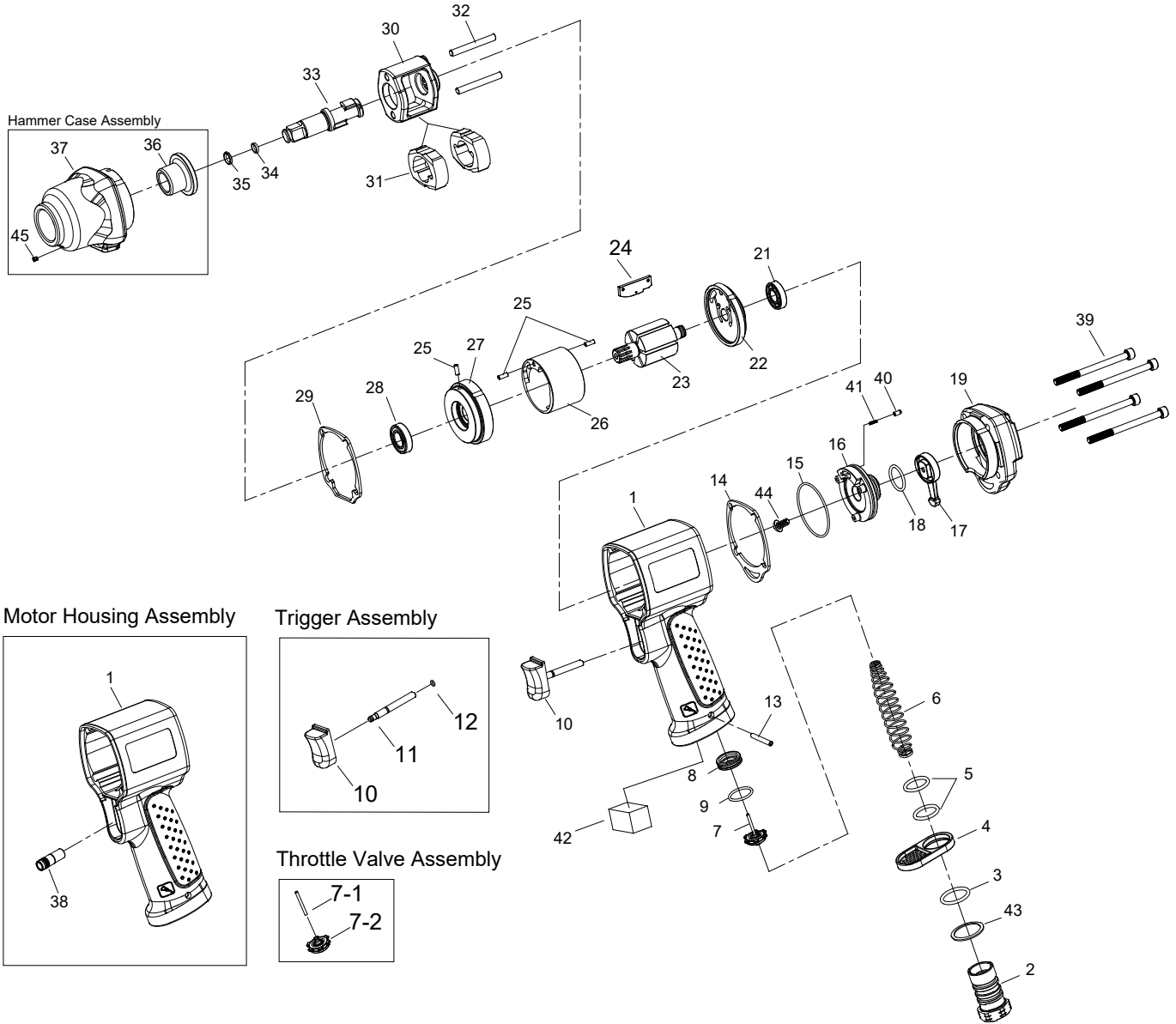

1485-VG

| INDEX NO. | DESCRIPTION | REQ'D NO. | INDEX NO. | DESCRIPTION | REQ'D NO. |
|-----------|---|-----------|-----------|---|-----------|
| ★ 1 | Motor Housing Assembly (incl. 38) | 1 | 24 | Rotor Blade | 6 |
| 2 | Air Inlet | 1 | 25 | Spring Pin | 3 |
| 3 | O-Ring | 1 | 26 | Cylinder | 1 |
| 4 | Exhaust Deflector | 1 | 27 | Front End Plate | 1 |
| 5 | O-Ring | 2 | 28 | Ball Bearing | 1 |
| 6 | Spring | 1 | 29 | Gasket | 1 |
| ★ 7 | Throttle Valve Assembly (incl. 7-1-7-2) | 1 | 30 | Hammer Frame | 1 |
| ● 7-1 | Throttle Valve Pin | 1 | 31 | Hammer | 2 |
| ● 7-2 | Throttle Valve | 1 | 32 | Hammer Pin | 2 |
| 8 | Throttle Valve Seat | 1 | 33 | Standard Anvil | 1 |
| 9 | O-Ring | 1 | 34 | O-Ring | 1 |
| ★ 10 | Trigger Assembly (incl.11.12) | 1 | 35 | Socket Retainer | 1 |
| ● 11 | Trigger Pin | 1 | ● 36 | Bushing | 1 |
| ● 12 | O-Ring | 1 | ★ 37 | Hammer Case Assembly (incl.36.45) | 1 |
| 13 | Spring Pin | 1 | ● 38 | Bushing | 1 |
| 14 | Gasket | 1 | 39 | Screw | 4 |
| 15 | O-Ring | 1 | 40 | Pin | 1 |
| 16 | Reverse Valve | 1 | 41 | Spring | 1 |
| 17 | Reverse Knob | 1 | 42 | Muffler Element | 1 |
| 18 | O-Ring | 1 | 43 | Spacer | 1 |
| 19 | Backhead | 1 | 44 | Screw | 1 |
| 21 | Ball Bearing | 1 | ● 45 | Grease Fitting | 1 |
| 22 | Rear End Plate | 1 | TK | Tune-Up Kit { incl.3.5 (2).6.9.14.15.17.18.24 (6) .29.34.35.41.42 } | |
| 23 | Rotor | 1 | | | |

★ Must be Purchased in Assembly Set

● Recommended not to be purchased alone due to assembly difficulty