

1/2" SQ. DR. SUPER DUTY AIR IMPACT WRENCH

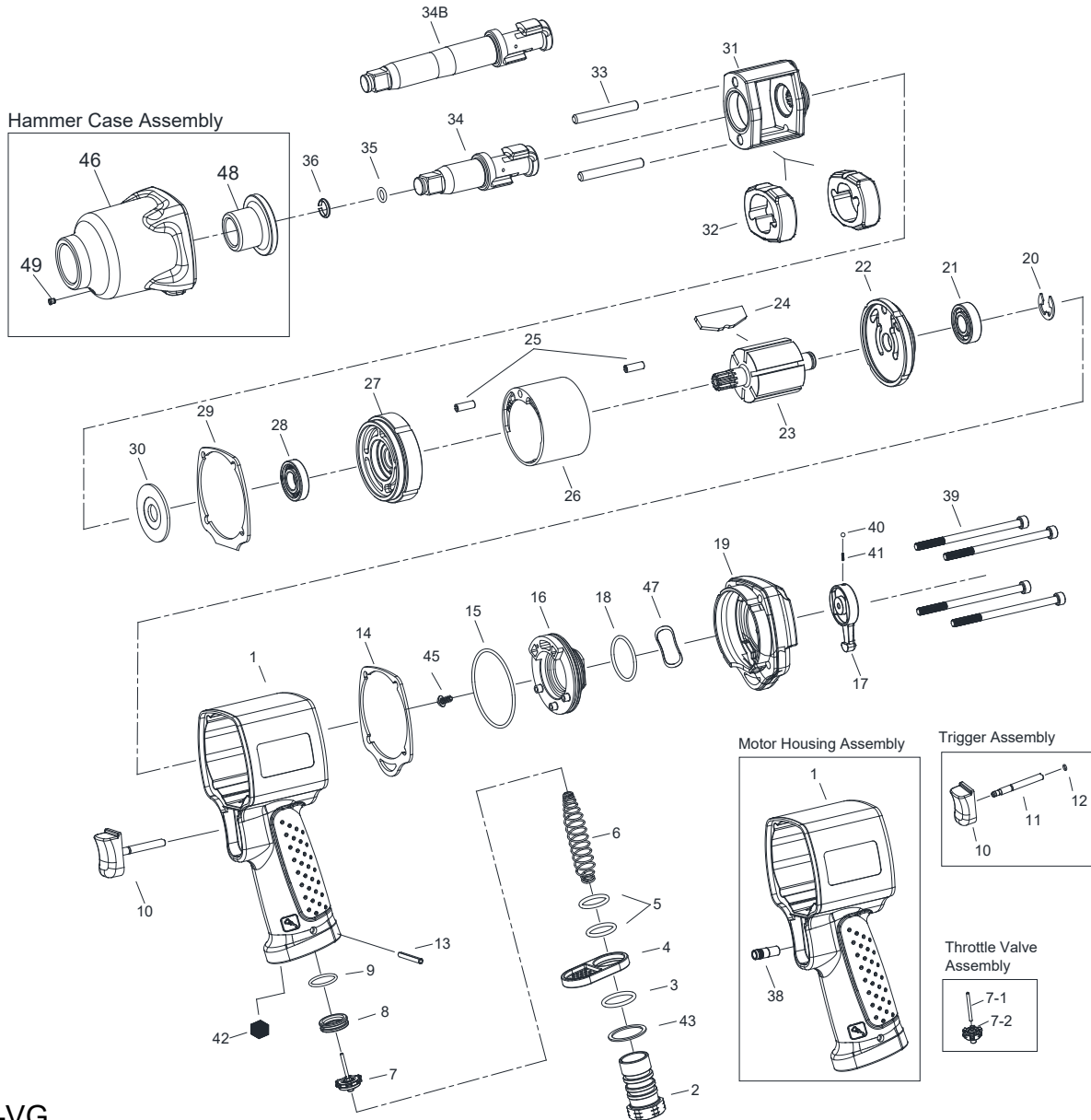

1488-VG

INDEX NO.	DESCRIPTION	REQ'D NO.	INDEX NO.	DESCRIPTION	REQ'D NO.
★ 1	Motor Housing Assembly (incl. 38)	1	25	Spring Pin	2
2	Air Inlet	1	26	Cylinder	1
3	O-Ring	1	27	Front End Plate	1
4	Exhaust Deflector	1	28	Ball Bearing	1
5	O-Ring	2	29	Gasket	1
6	Spring	1	30	Washer	1
★ 7	Throttle Valve Assembly (incl. 7-1,7-2)	1	31	Hammer Frame	1
● 7-1	Throttle Valve Pin	1	32	Hammer	2
● 7-2	Throttle Valve	1	33	Hammer Pin	2
8	Throttle Valve Seat	1	34	Standard Anvil	1
9	O-Ring	1	34B	2" Extended Anvil	1
★ 10	Trigger Assembly (incl.11,12)	1	35	O-Ring	1
● 11	Trigger Pin	1	36	Socket Retainer	1
● 12	O-Ring	1	● 38	Bushing	1
13	Spring Pin	1	39	Screw	4
14	Gasket	1	40	Steel Ball	1
15	O-Ring	1	41	Spring	1
16	Reverse Valve	1	42	Muffler Element	1
17	Reverse Knob	1	43	Spacer	1
18	O-Ring	1	45	Screw	1
19	Backhead	1	★ 46	Hammer Case Assembly (incl.48,49)	1
20	Retainer	1	47	Washer	1
21	Ball Bearing	1	● 48	Bushing	1
22	Rear End Plate	1	● 49	Grease Fitting	1
23	Rotor	1	TK	Tune-Up Kit { incl.3.5 (2) .6.9.14.15.17.18.24 (6) .29.35.36.40.41.42 }	
24	Rotor Blade	6			

★ Must be Purchased in Assembly Set

● Recommended not to be purchased alone due to assembly difficulty

20181102R1