

1" SQ. DR. SUPER DUTY IMPACT WRENCH

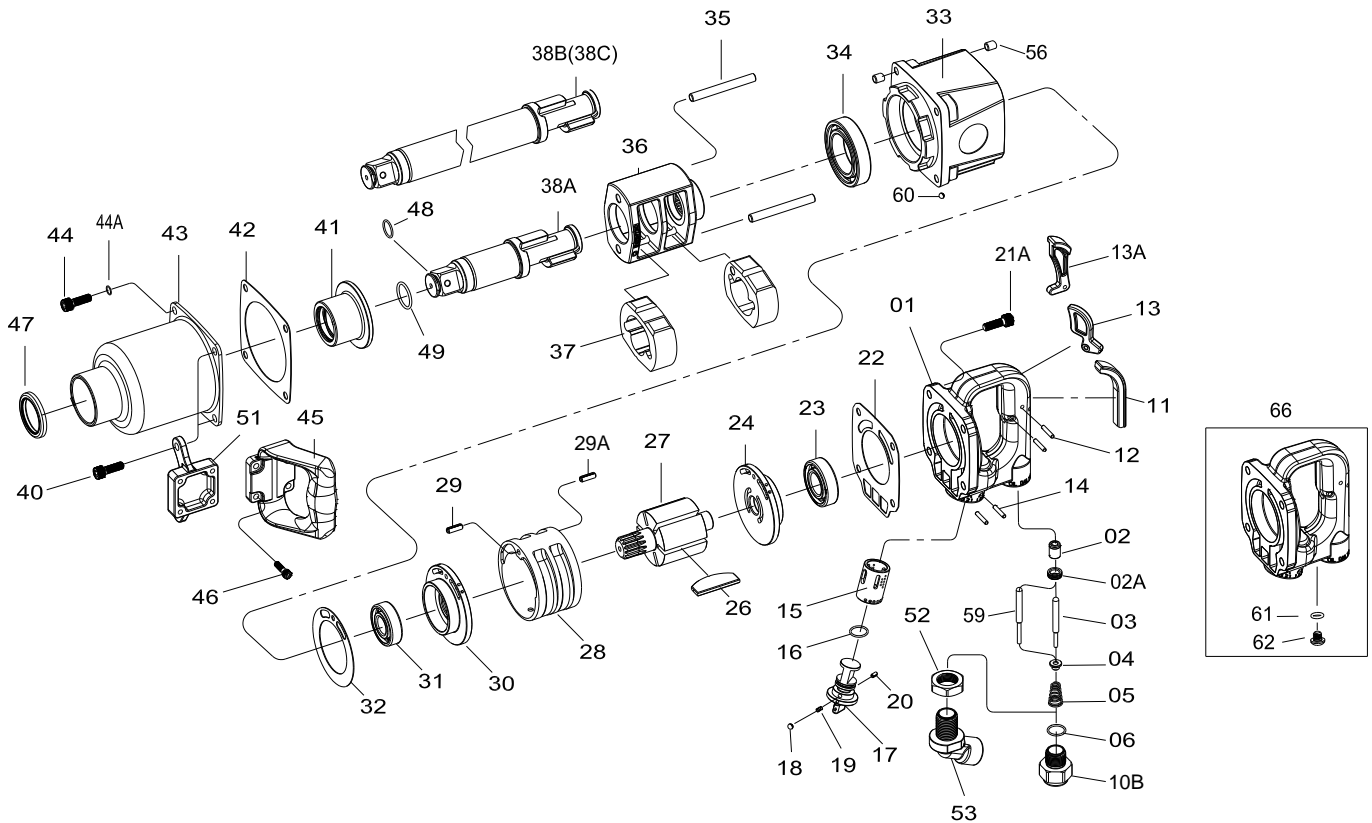

1837/1837-3/1837-6

INDEX NO.	DESCRIPTION	REQ'D NO.	INDEX NO.	DESCRIPTION	REQ'D NO.
★ 1	Backhead Assembly (incl.2.15)	1	32	Gasket	1
● 2	Bushing	1	★ 33	Housing Assembly (incl.56 .60)	1
2A	Throttle Valve Seat	1	34	Ball Bearing	1
3	Throttle Valve Plunger (for Inside Trigger)	1	35	Hammer Pin	2
4	Throttle Valve	1	36	Hammer Frame	1
5	Spring	1	37	Hammer	2
6	O-Ring	1	38A	Standard Anvil (for KI-1837)	1
10B	Straight Air Inlet (Option.)	1	38B	6" Extended Anvil (for KI-1837-6)	1
11	Rubber Cap (for Inside Trigger)	1	38C	3" Extended Anvil (for KI-1837-3)	1
12	Pin	2	40	Screw	2
13	Inside Trigger (Option)	1	41	Bushing	1
13A	Outside Trigger (Option)	1	42	Gasket	1
14	Spring Pin	2	43	Hammer Case	1
● 15	Reverse Valve Bushing	1	★ 44	Screw Assembly (incl.44A)	2
16	O-Ring	1	● 44A	Spring Washer	2
★ 17	Reverse Valve Assembly (incl.20)	1	45	Side Spade Handle	1
18	Steel Ball	1	46	Screw	4
19	Spring	1	47	Oil Seal	1
● 20	Spring Pin	1	48	O-Ring	1
21A	Screw	4	49	Socket Retainer	1
22	Gasket	1	51	Support Handle	1
● 23	Ball Bearing	1	52	Lock Nut (Option)	1
★ 24	Rear End Plate Assembly (incl.23)	1	53	Air Inlet (Option)	1
26	Rotor Blade	6	● 56	Heli-Coil	8
27	Rotor	1	59	Throttle Valve Plunger (for Outside Trigger)	1
28	Cylinder	1	● 60	Steel Ball	4
29	Spring Pin	1	● 61	O-Ring	1
29A	Spring Pin	1	● 62	Screw	1
★ 30	Front End Plate Assembly (incl.31)	1	★ 66	Backhead Assembly (incl.2.15.61.62) (Option)	1
● 31	Ball Bearing	1	TK	Tune-Up Kit { incl. 5.6.16.18.19.22.23.26 (6) .31.32.34.42.48.49 }	

★ Must be Purchased in Assembly Set

● Recommended not to be purchased alone due to assembly difficulty

20140623R4