

1" SQ. DR. SUPER DUTY IMPACT WRENCH

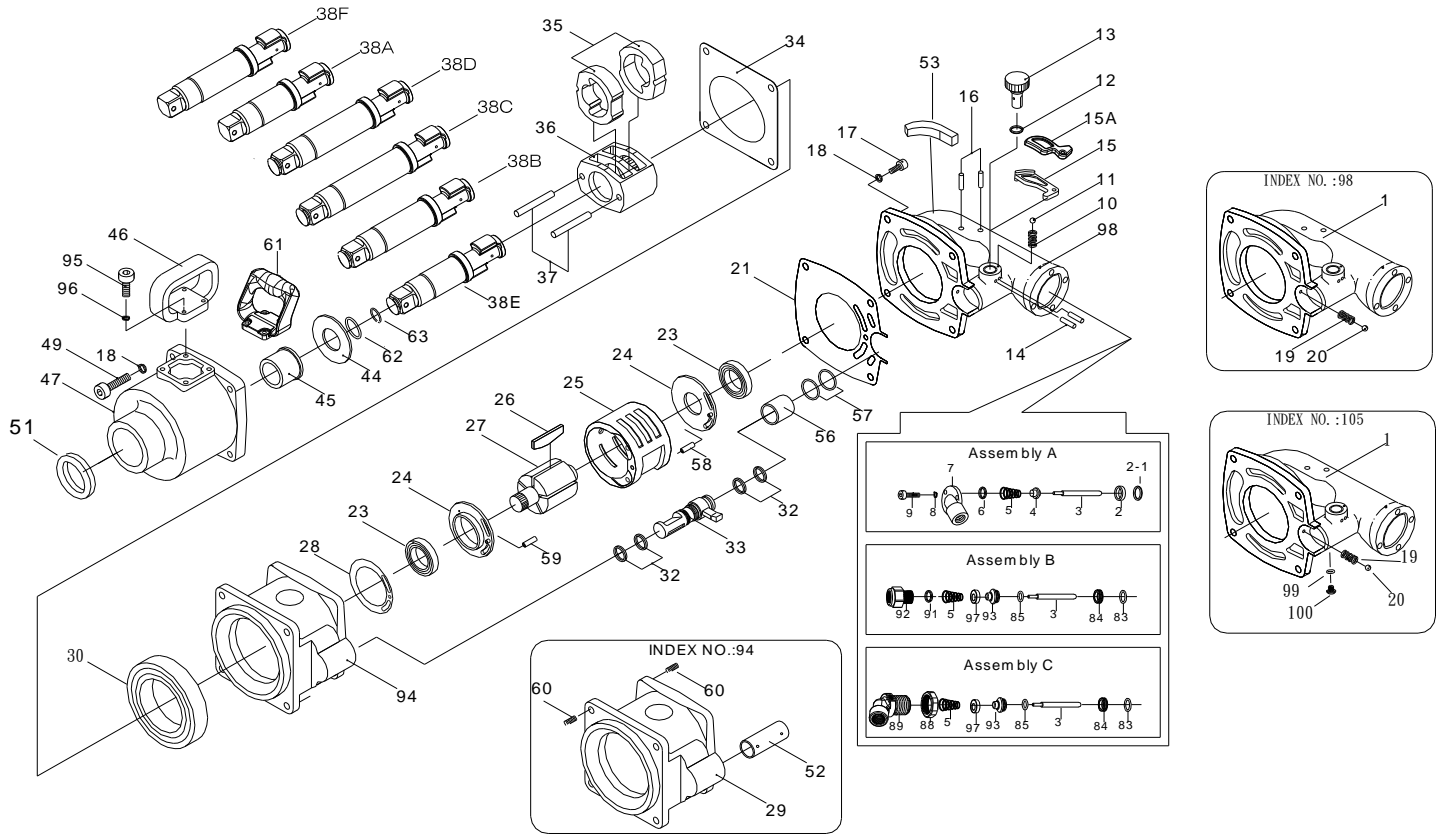

40/40-6/40-7/40-8

INDEX NO.	DESCRIPTION	REQ'D NO.	INDEX NO.	DESCRIPTION	REQ'D NO.
● 1	Backhead	1	38B	6" Extended Anvil (for KI-40-6)	1
● 2	Throttle Valve Seat	1	38C	8" Extended Anvil (for KI-40-8)	1
● 2-1	Throttle Valve Washer	1	38D	7" Extended Anvil (for KI-40-7)	1
● 3	Throttle Valve Plunger	1	38E	Standard Anvil (for KI-40)	1
● 4	Throttle Valve	1	38F	6" Extended Anvil (Option)	1
● 5	Spring	1	44	Washer	1
● 6	O-Ring	1	45	Bushing	1
★ 7	Air Inlet Assembly { incl.2.2-1.3.4.5.6.8(4).9(4) } (Option)	1	46	Side Spade Handle (Option)	1
● 8	Spring Washer	4	47	Hammer Case	1
★ 9	Screw Assembly { incl.8 (4) }	4	★ 49	Screw Assembly { incl.18 (4) }	4
10	Spring	1	51	Oil Seal	1
11	Steel Ball	1	● 52	Reverse Valve Bushing	1
12	O-Ring	1	53	Rubber Cap (for Inside Trigger)	1
13	Air Regulator	1	56	Bushing	1
14	Spring Pin	2	57	O-Ring	2
15	Outside Trigger (Option)	1	58	Spring Pin	1
15A	Inside Trigger (Option)	1	59	Spring Pin	1
16	Spring Pin	2	● 60	Heli-Coil	8
★ 17	Screw Assembly { incl.18 (4) }	4	61	Side Spade Handle (Option)	1
● 18	Spring Washer	8	62	Socket Retainer	1
● 19	Spring	1	63	O-Ring	1
● 20	Steel Ball	1	● 83	O-Ring	1
21	Gasket	1	● 84	Throttle Valve Seat	1
● 23	Ball Bearing	2	● 85	O-Ring	1
★ 24	Rear End Plate And Front End Plate Assembly (incl.23)	2	● 88	Angle Air Inlet Nut	1
25	Cylinder	1	★ 89	Angle Air Inlet Assembly (incl.3.5.83.84.85.88.89.93.97) (Option)	1
26	Rotor Blade	7	91	O-Ring	1
27	Rotor	1	★ 92	Air Inlet Assembly (incl.3.5.83.84.91.92.93.97) (Option)	1
28	Gasket	1	● 93	Throttle Valve	1
● 29	Motor Housing	1	★ 94	Housing Assembly { incl.29.52.60(8) }	1
30	Ball Bearing	1	★ 95	Screw Assembly { incl.96 (4) }	4
32	O-Ring	4	● 96	Spring Washer	4
33	Reverse Valve	1	● 97	Valve Ring	1
34	Gasket	1	★ 98	Backhead Assembly (incl.1.19.20) (Option)	1
35	Hammer	2	99	O-Ring	1
36	Hammer Frame	1	100	Screw	4
37	Hammer Pin	2	★ 105	Backhead Assembly (incl.1.19.20.99.100) (Option)	1
38A	Standard Anvil (Option)	1	TK	Tune-Up Kit { 5.6.10.11.12.19.20.21.23(2).26(7).28.30.32(4).34.57(2).62.63 }	

★ Must be Purchased in Assembly Set

● Recommended not to be purchased alone due to assembly difficulty

PA3-00040-5

20090720R4