

1/2" SQ. DR.SUPER DUTY IMPACT WRENCH

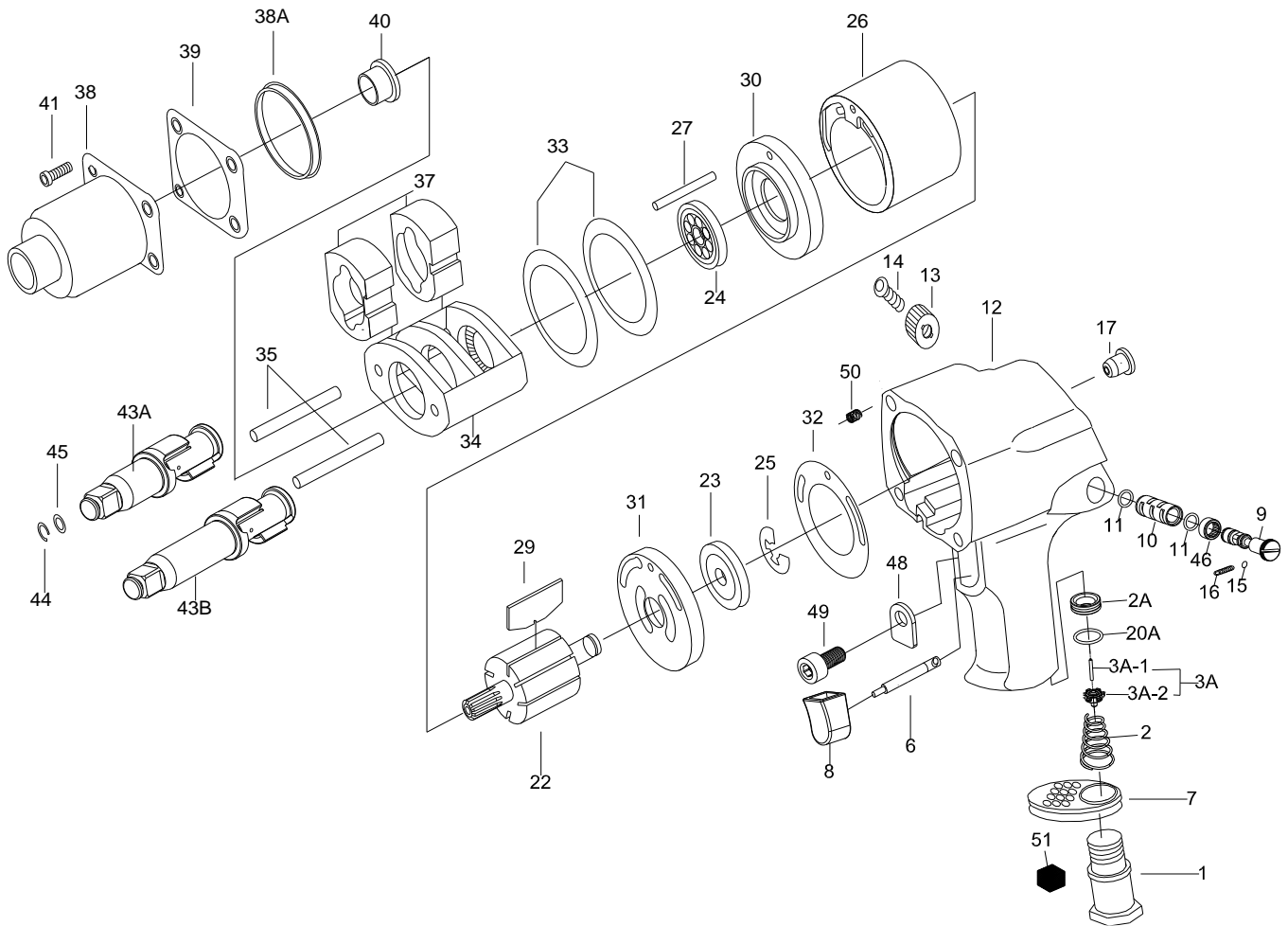

8571 / 8571-2

INDEX NO.	DESCRIPTION	REQ'D NO.	INDEX NO.	DESCRIPTION	REQ'D NO.
1	Air Inlet	1	27	Cylinder Dowel	1
2	Spring	1	29	Rotor Blade	6
★ 2A	Throttle Valve Seat	1	30	Front End Plate	1
★ 3A	Throttle Valve Assembly (incl.3A-1.3A-2)	1	31	Rear End Plate	1
● 3A-1	Throttle Valve Pin	1	32	Gasket	1
● 3A-2	Throttle Valve	1	33	Motor Clamp Washer	2
● 6	Trigger Pin	1	34	Hammer Frame	1
7	Exhaust Deflector	1	35	Hammer Pin	2
★ 8	Trigger Assembly (incl.6)	1	37	Hammer	2
9	Reverse Valve	1	38	Hammer Case	1
● 10	Reverse Valve Bushing	1	38A	Separator	1
11	O-Ring	2	39	Gasket	1
★ 12	Housing Assembly { incl.10.17.46.50(4) }	1	40	Bushing	1
13	Reverse Valve Knob	1	41	Screw	4
14	Screw	1	43A	Standard Anvil (for KI-8571)	1
15	Steel Ball	1	43B	2" Extended Anvil (for KI-8571-2)	1
16	Spring	1	44	Socket Retainer	1
● 17	Grease Fitting	1	45	O-Ring	1
20A	O-Ring	1	● 46	Reverse Valve Bushing Gear	1
22	Rotor	1	48	Trigger Retainer	1
23	Ball Bearing	1	49	Screw	1
24	Ball Bearing	1	● 50	Heli-Coil	4
25	Retainer	1	51	Muffer Element	1
26	Cylinder	1	TK	Tune-Up Kit { 2.11(2).15.16.23.24.25.29(6).32.39.44.45.51 }	1

★ Must be Purchased in Assembly Set

● Recommended not to be purchased alone due to assembly difficu

PA1-08571-2

20090409R1