

1/2" SQ. DR.SUPER DUTY IMPACT WRENCH

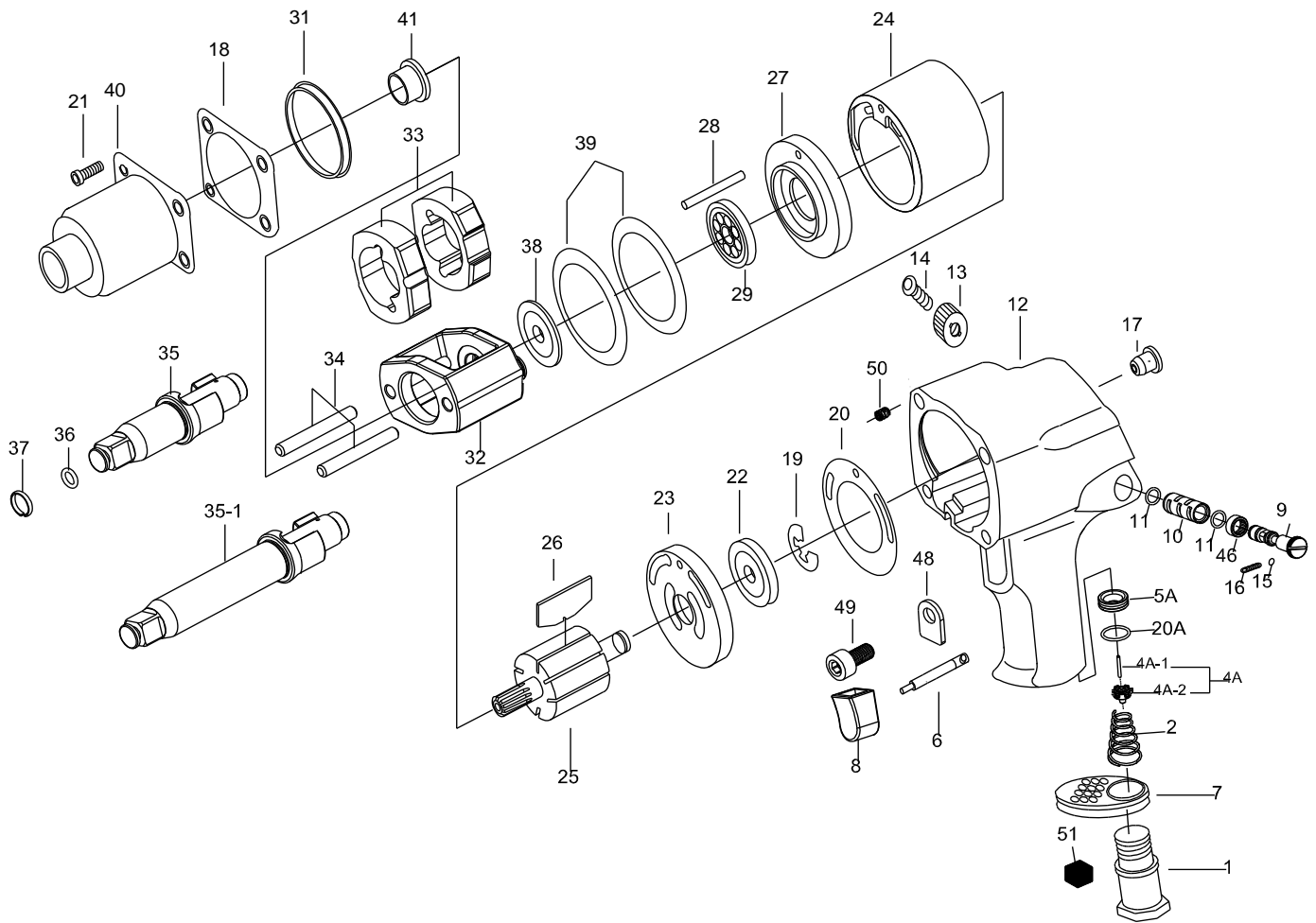

859/859-2

INDEX NO.	DESCRIPTION	REQ'D NO.	INDEX NO.	DESCRIPTION	REQ'D NO.
1	Air Inlet	1	24	Cylinder	1
2	Spring	1	25	Rotor	1
★ 4A	Throttle Valve Assembly (incl.4A-1.4A-2)	1	26	Rotor Blade	6
● 4A-1	Throttle Valve Pin	1	27	Front End Plate	1
● 4A-2	Throttle Valve	1	28	Cylinder Dowel	1
5A	Throttle Valve Seat	1	29	Ball Bearing	1
● 6	Trigger Pin	1	31	Separator	1
7	Exhaust Deflector	1	32	Hammer Frame	1
★ 8	Trigger Assembly (incl.6)	1	33	Hammer	2
9	Reverse Valve	1	34	Hammer Pin	2
● 10	Reverse Valve Bushing	1	35	Standard Anvil (for KI-859)	1
11	O-Ring	2	35-1	2" Extended Anvil (for KI-859-2)	1
★ 12	Housing Assembly (incl.10.17.46.50(4))	1	36	O-Ring	1
13	Regulator Valve Knob	1	37	Socket Retainer	1
14	Screw	1	38	Washer	1
15	Steel Ball	1	39	Motor Clamp Washer	2
16	Spring	1	40	Hammer Case	1
● 17	Grease Fitting	1	41	Bushing	1
18	Gasket	1	● 46	Reverse Valve Bushing Gear	1
19	Retainer	1	48	Trigger Retainer	1
20	Gasket	1	49	Screw	1
20A	O-Ring	1	● 50	Heli-Coil	4
21	Screw	4	51	Muffler Element	1
22	Ball Bearing	1			
23	Rear End Plate	1	TK	Tune-Up Kit {2.11(2).15.16.18.19.20.20A.22.26(6).29.36.37.51}	

★ Must be Purchased in Assembly Set

● Recommended not to be purchased alone due to assembly difficulty

PA1-00859-2

20090415R2