

HEAVY DUTY AIR NEEDLE SCALER

氣動針束除銹機

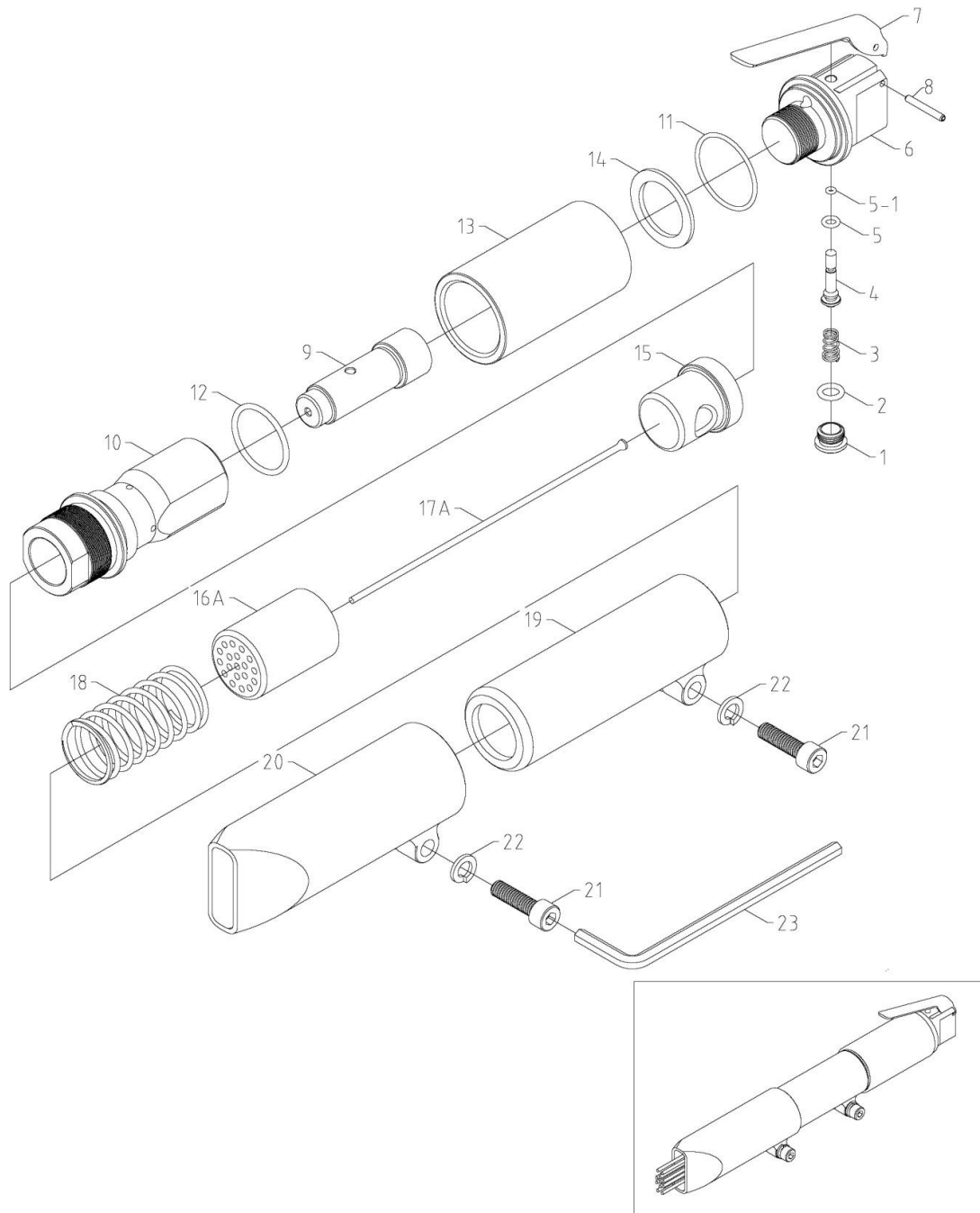

4716

INDEX NO.	DESCRIPTION	中文名稱	REQ'D NO.	INDEX NO.	DESCRIPTION	中文名稱	REQ'D NO.
01	Valve Cap	進氣閥帽	1	13	Cylinder Sleeve	氣缸套筒	1
02	O-Ring	O型環	1	14	Washer	連結螺帽	1
03	Valve Spring	彈簧	1	15	Needle Driver	擊錘	1
04	Valve Stem	進氣頂桿	1	16A	Needle Holder (Ø 3×19 Holes)	鋼針座(3mm)	1
05	O-Ring	O型環	1	16B	Needle Holder (Ø 2×29 Holes) (Option)	鋼針座(2mm)(選擇)	1
05-1	O-Ring	O型環	1	17A	Needle (Ø 3×180L)	鋼針組(3mm)	19
06	Backhead	進氣主體	1	17B	Needle (Ø 2×180L) (Option)	鋼針組(2mm)(選擇)	29
07	Lever	壓板板機	1	18	Compression Spring	彈簧	1
08	Spring Pin	板機固定銷	1	19	Intermediate Tube	中段護管	1
09	Piston	活塞	1	20	Front Tube	前護管	1
10	Cylinder	氣缸	1	21	Cap Head Screw	螺絲	2
11	O-Ring	O型環	1	22	Spring Washer	墊圈	2
12	O-Ring	O型環	1	23	Hex. Wrench (6mm)	六角板手(6mm)	1

0000.00.00

2013.05.23 2019.07.17