

HEAVY DUTY AIR NEEDLE SCALER

氣動針束除銹機

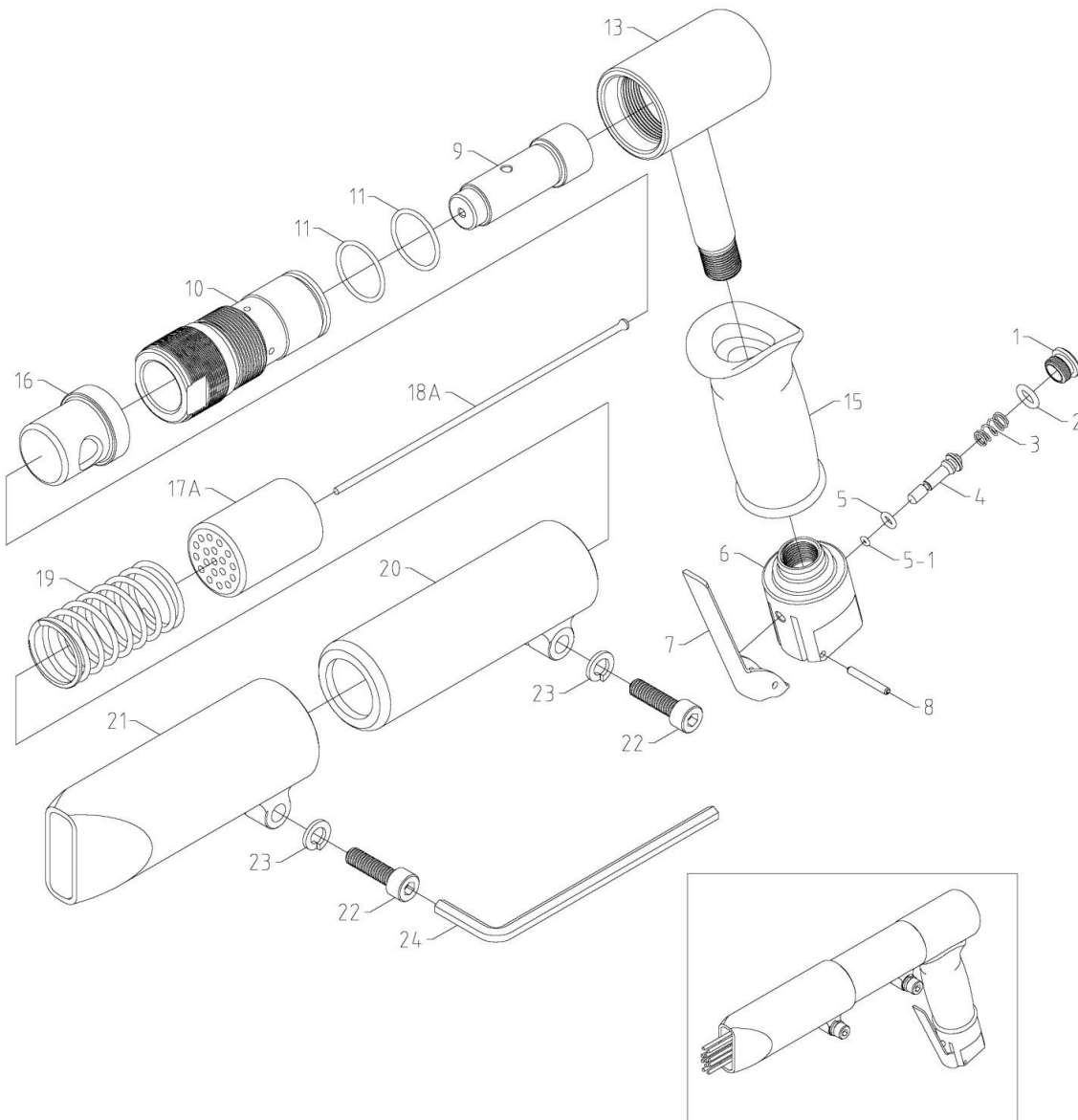

4722-P

INDEX NO.	DESCRIPTION	中文名稱	REQ'D NO.	INDEX NO.	DESCRIPTION	中文名稱	REQ'D NO.
01	Valve Cap	進氣閥帽	1	15	Rubber Grip	橡膠護套	1
02	O-Ring	O型環	1	16	Needle Driver	鋼針驅動	1
03	Valve Spring	彈簧	1	17A	Needle Holder (φ3×19 Holes)	鋼針座(3mm)	1
04	Valve Stem	進氣頂桿	1	17B	Needle Holder (φ2×29 Holes) (Option)	鋼針座(2mm)(選擇)	1
05	O-Ring	O型環	1	18A	Needle (φ3×180L)	鋼針組(3mm×180L)	19
05-1	O-Ring	O型環	1	18B	Needle (φ2×180L) (Option)	鋼針組(2mm×180L)(選擇)	29
06	Backhead	進氣主體	1	19	Compression Spring	彈簧	1
07	Lever	壓板扳機	1	20	Intermediate Tube	中段護管	1
08	Spring Pin	板機固定銷	1	21	Front Tube	前護管	1
09	Piston	活塞	1	22	Cap Head Screw	螺絲	2
10	Cylinder	氣缸	1	23	Spring Washer	墊圈	2
11	O-Ring	O型環	2	24	Hex. Wrench (6mm)	六角扳手(6mm)	1
13	Handle	手柄	1				

0000.00.00

2017.09.27 2019.07.17