

HEAVY DUTY AIR GASKET SCRAPER

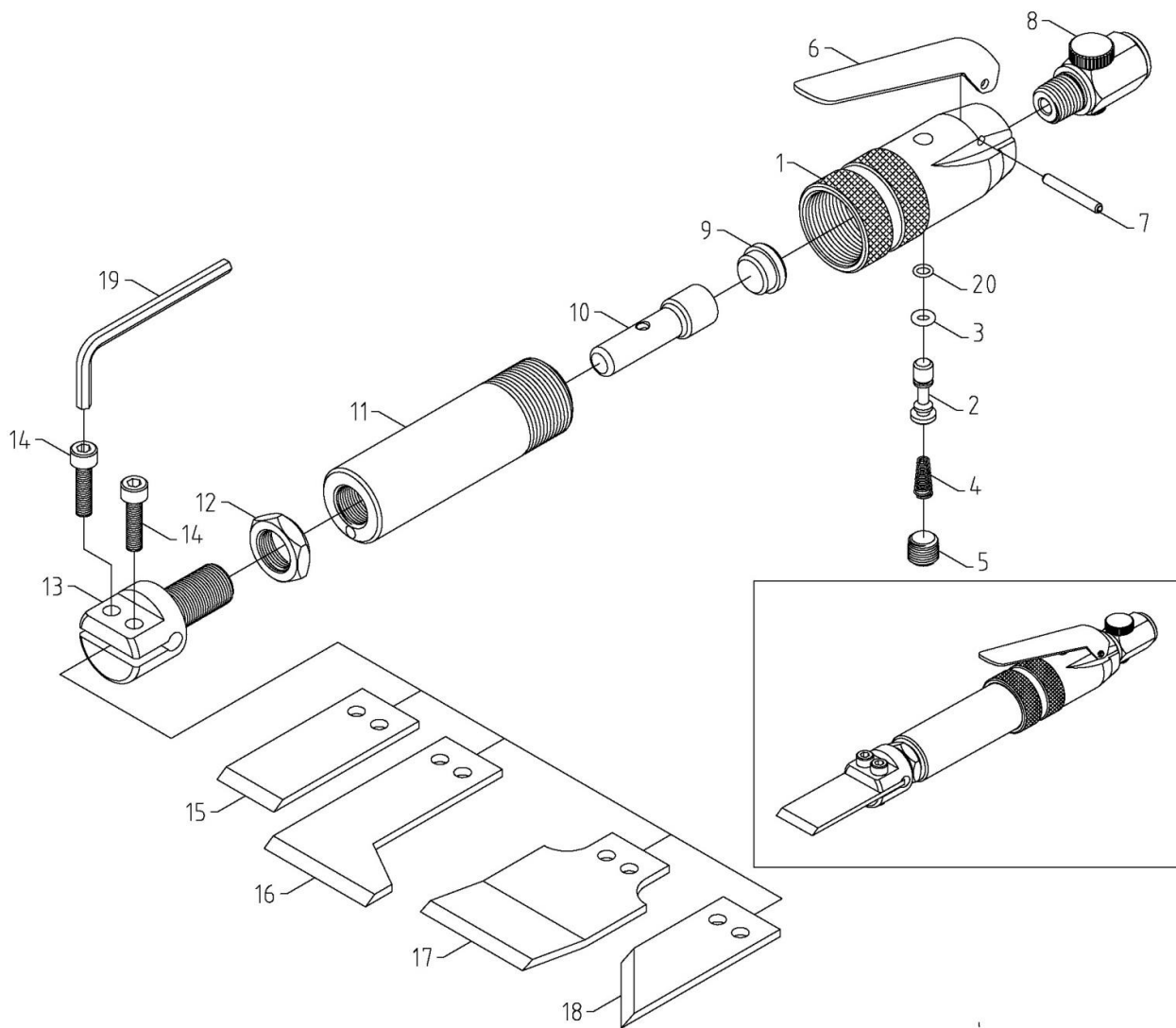

4741

INDEX NO.	DESCRIPTION	REQ'D NO.	INDEX NO.	DESCRIPTION	REQ'D NO.
01	Backhead	1	11	Cylinder	1
02	Valve Stem	1	12	Nut	1
03	O-Ring	1	13	Blade Holder	1
04	Valve Spring	1	14	Cap Head Screw	2
05	Socket Set Screw	1	15	Blade-Flat (25mm)	1
06	Lever	1	16	Blade-L-Shaped (45mm) (Option)	1
07	Spring Pin	1	17	Blade-Bending (45mm) (Option)	1
08	Regulator Kit	1	18	Blade-Angle (25mm) (Option)	1
09	Cylinder Cap	1	19	Hex. Wrench (4mm)	1
10	Piston	1	20	O-Ring	1

0000.00.00

2019.01.10 2019.07.16