

HEAVY DUTY AIR ANGLE SANDER

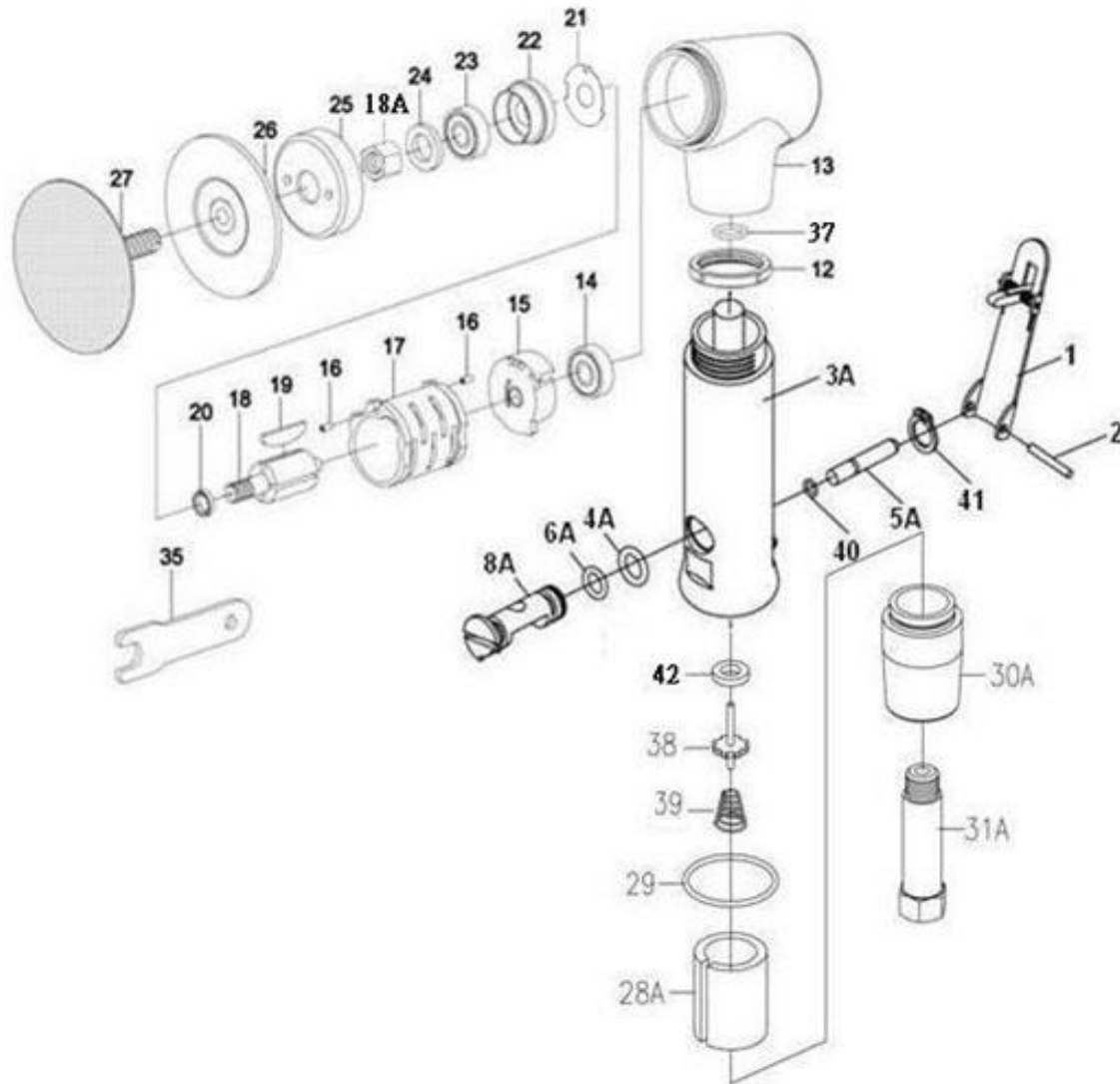

6516-XAR2

INDEX NO.	DESCRIPTION	REQ'D NO.	INDEX NO.	DESCRIPTION	REQ'D NO.
01	Throttle Lever	1	22	Front End Plate	1
02	Spring Pin	1	23	Ball Bearing	1
03A	Housing	1	24	Silencer	1
04A	O-Ring	1	25	Cover	1
05A	Valve Stem	1	26	Disc Holder	1
06A	O-Ring	1	27	Sanding Disc (#80)	1
08A	Air Controller	1	28A	Silencer	1
12	Lock Nut	1	29	O-Ring	1
13	Housing	1	30A	Air Deflector	1
14	Ball Bearing	1	31A	Air Inlet	1
15	Rear End Plate	1	35	Wrench (11mm)	1
16	Pin	2	37	O-Ring	1
17	Cylinder	1	38	Valve Stem	1
18	Rotor	1	39	Spring	1
18A	Nut	1	40	O-Ring	1
19	Rotor Blade	4	41	Snap Ring	1
20	Spacer	1	42	Seal	1
21	Steel Plate	1			

0000.00.00

2014.08.15