

# 5" SUPER DUTY AIR ANGLE GRINDER

## 氣動砂輪機

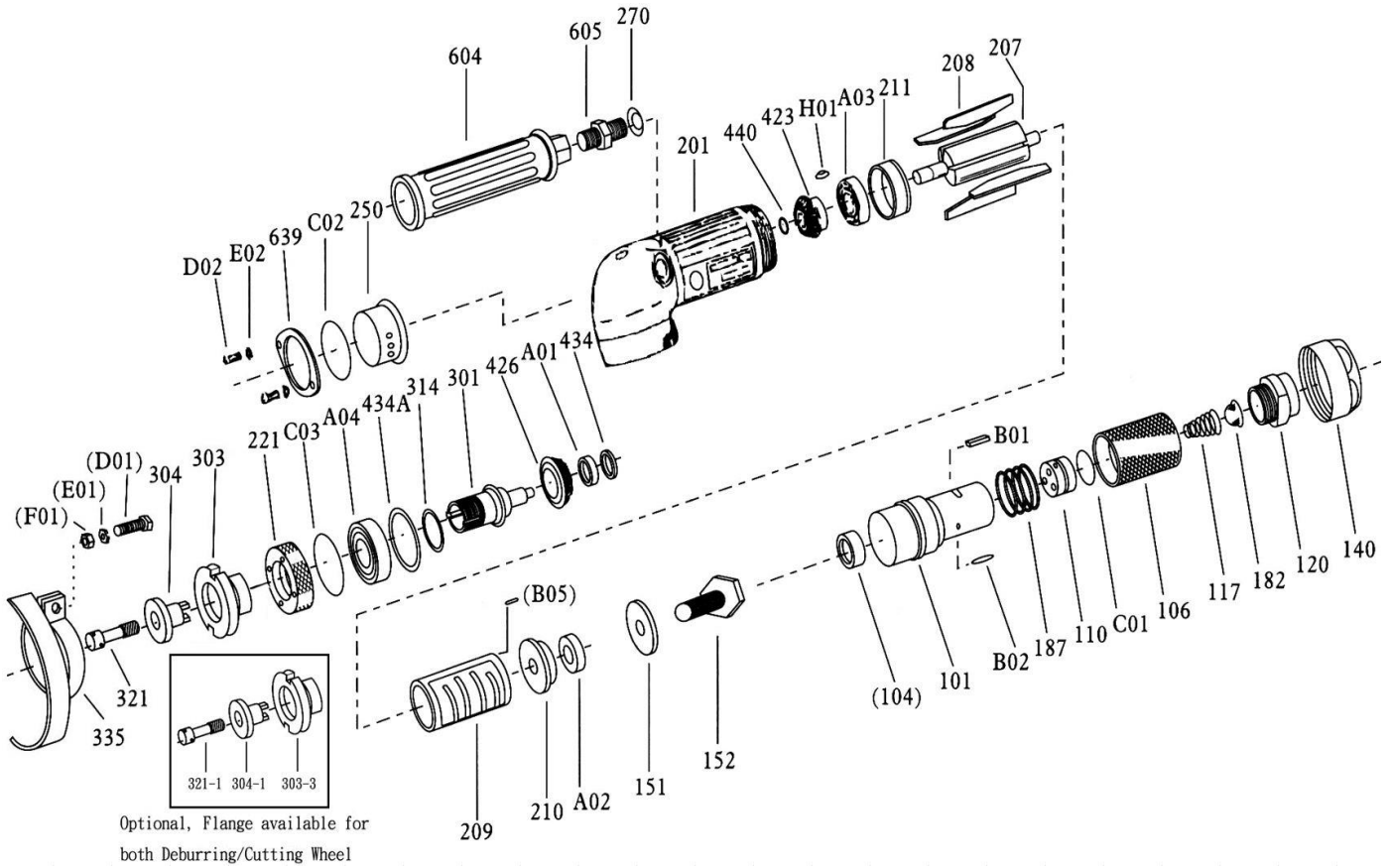

6708

INDEX NO.	DESCRIPTION	中文名稱	REQ'D NO.	INDEX NO.	DESCRIPTION	中文名稱	REQ'D NO.
101	Housing Cover	手柄後蓋	1	304	Wheel Flange (B)	砂輪凸緣(B)	1
(104)	Bushing	導套	1	304-1	Flange(B) For Deburring Wheel (Option)	切斷片凸緣(B)(選擇)	1
106	Throttle Valve Handle	進氣開關	1	314	Wheel Spindle Washer (T=0.5)	主軸墊片(T=0.5)	1
110	Throttle Valve	進氣閥	1	314	Wheel Spindle Washer (T=0.3)	主軸墊片(T=0.3)	1
117	Throttle Valve Spring	進氣閥彈簧	1	314	Wheel Spindle Washer (T=0.2)	主軸墊片(T=0.2)	1
120	Throttle Valve Cover (PT)	3/8"進氣口(PT)	1	321	Detent Bolt	擊止螺栓	1
120	Throttle Valve Cover (NPT)	3/8"進氣口(NPT)	1	321-1	Detent Bolt (Option)	擊止螺栓(選擇)	1
140	Cup Nut	螺帽	1	335	Wheel Guard	砂輪護蓋	1
151	Top Plate Washer	後端板墊圈	1	(D01)	Hexagon Bolt	六角螺栓	1
152	Lock Screw	螺絲	1	(E01)	Spring Washer	墊圈	1
182	Strainer	濾網	1	(F01)	Nut	螺帽	1
187	Throttle Valve Handle Spring	進氣開關彈簧	1	423	Bevel Pinion	傳動齒輪	1
B01	Needle Roller	滾針	1	426	Bevel Gear	傘形齒輪	1
B02	Needle Roller	滾針	1	434	Bearing Washer	軸承墊圈	1
C01	O-Ring	O型環	1	434A	Bearing Washer	軸承墊圈	1
201	Housing	手柄	1	440	Ring	環	1
207	Rotor	轉子	1	604	Dead Handle	輔助握把	1
208	Rotor Blade	葉片	4	605	Dead Handle Joint	輔助握把接頭	1
209	Cylinder	氣缸	1	639	Exhaust Cover Holder	排氣罩固定片	1
(B05)	Spring Pin	彈簧銷	1	A01	Ball Bearing	滾珠軸承(626)	1
210	Cylinder Upper Plate	後端板	1	A02	Ball Bearing	滾珠軸承(609)	1
211	Cylinder Lower Plate	前端板	1	A03	Ball Bearing	滾珠軸承(6200)	1
221	Spindle Bearing Cover	主軸軸承蓋	1	A04	Ball Bearing	滾珠軸承(6004)	1
250	Exhaust Cover	排氣罩	1	C03	O-Ring	O型環	1
C02	O-Ring	O型環	1	D02	Cap Screw	螺絲	2
270	Conical Spring Washer	錐形彈簧墊圈	1	E02	Spring Washer	墊圈	2
301	Wheel Spindle	砂輪主軸	1	H01	Key	鍵	1
303	Wheel Flange (A)	砂輪凸緣(A)	1				
303-3	Flange(A) For Deburring Wheel (Option)	切斷片凸緣(A)(選擇)	1				

0000.00.00

2010.06.22 2019.08.12