

2" HEAVY DUTY AIR ANGLE GRINDER

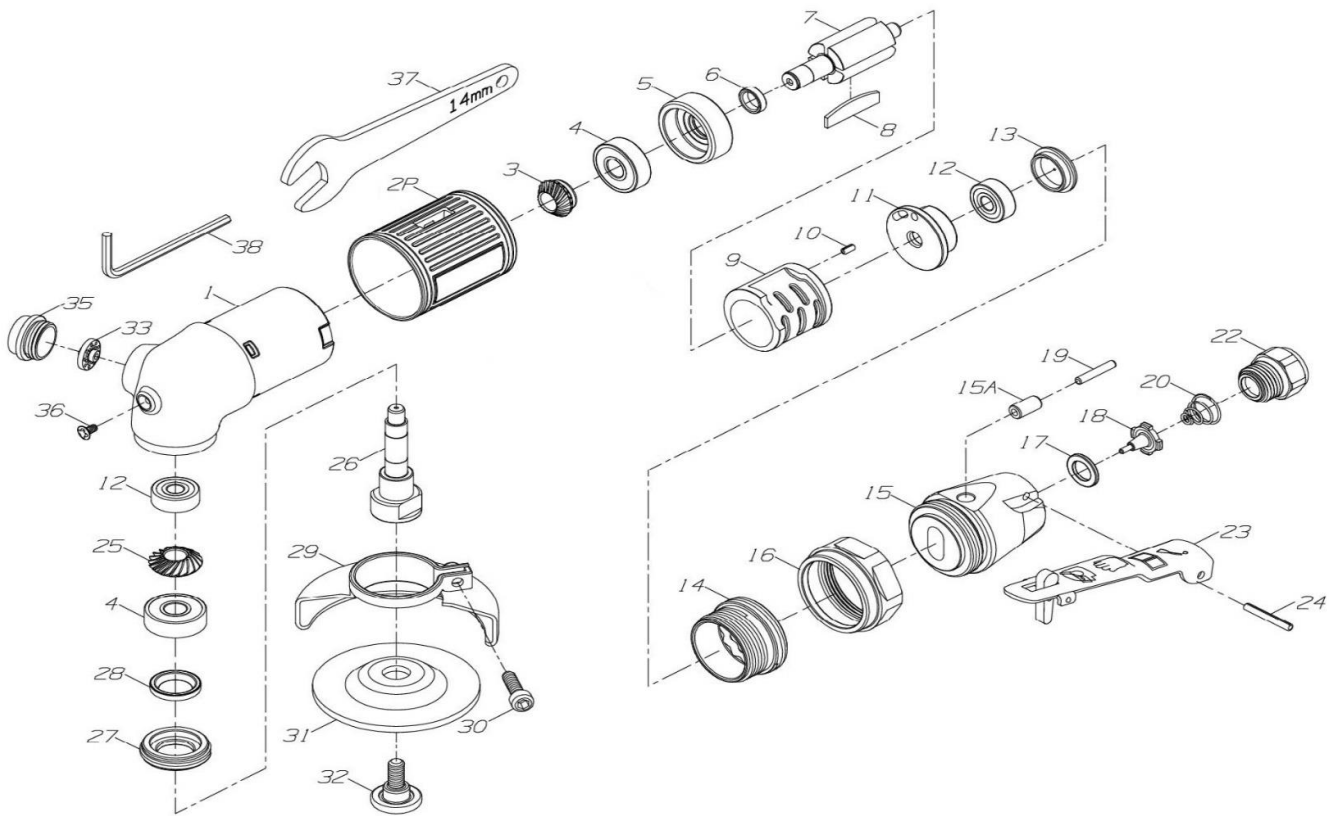

6810-SL

INDEX NO.	DESCRIPTION	REQ'D NO.	INDEX NO.	DESCRIPTION	REQ'D NO.
01	Housing	1	19	Pin	1
02P	Housing Sleeve	1	20	Spring	1
03	Bevel Pinion	1	22	Inlet Bushing	1
04	Ball Bearing	2	23	Safety Lever	1
05	Front End Plate	1	24	Pin	1
06	Spacer	1	25	Bevel Gear	1
07	Rotor	1	26	Spindle	1
08	Rotor Blade	4	27	Spindle Cover	1
09	Cylinder	1	28	Oil Seal	1
10	Pin	1	29	2" Wheel Guard	1
11	Rear End Plate	1	30	Screw	1
12	Ball Bearing	2	31	2" Grinding Wheel (#60) (Option)	1
13	Motor Cover	1		2" Grinding Wheel (#80) (Option)	
14	Valve Adaptor	1	32	Lock Screw	1
15	Valve Body	1	33	Exhaust Deflector	1
15A	Bushing	1	35	Deflector Cover	1
16	Clamp Nut	1	36	Screw	1
17	Spacer	1	37	Wrench (14mm)	1
18	Controller	1	38	Hex. Wrench (5mm)	1

0000.00.00

2020.02.20 2021.01.19