

# 7" HEAVY DUTY AIR ANGLE GRINDER

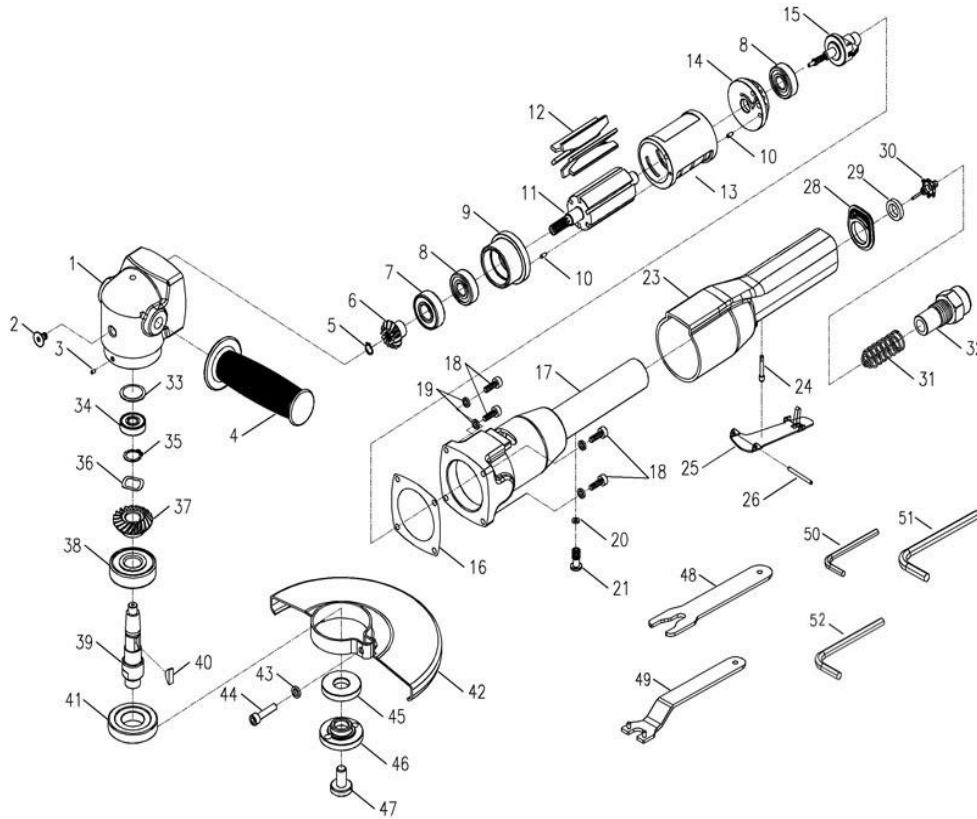

6817

INDEX NO.	DESCRIPTION	REQ'D NO.	INDEX NO.	DESCRIPTION	REQ'D NO.
01	Gear Housing	1	33	Felt	1
02	Screw	1	34	Ball Bearing	1
03	Set Screw	1	35	Retaining Ring	1
04	Dead Handle	1	36	Wave Washer	1
05	Retaining Ring	1	37	Bevel Gear	1
06	Bevel Pinion	1	38	Ball Bearing	1
07	Ball Bearing	1	39	Gear Shaft (5/8-11) (Option)	1
08	Ball Bearing	2		Gear Shaft (M16×P2.0) (Option)	
09	Front End Plate	1		Gear Shaft (M14×P2.0)	
10	Spring Pin	2	40	Key	1
11	Rotor	1	41	Nut	1
12	Rotor Blade	6	42	Disc Cover (7")	1
13	Cylinder	1	43	Spring Washer	1
14	Rear End Plate	1	44	Screw	1
15	Pendulum Set	1 set	45	Disc Receiver (5/8-11) (Option)	1
16	Gasket	1		Disc Receiver (M16×P2.0) (Option)	
17	Motor Housing	1		Disc Receiver (M14×P2.0)	
18	Screw	4	46	Disc Nut (5/8-11) (Option)	1
19	Spring Washer	4		Disc Nut (M16×P2.0) (Option)	
20	O-Ring	1		Disc Nut (M14×P2.0)	
21	Valve Bushing	1	47	8mm Hex. Disc Stop Screw (For 5/8-11 & M16×P2.0 Spindle)(Option)	1
23	Handle	1		6mm Hex. Disc Stop Screw (M14×P2.0)	
24	Valve Pin	1	48	19mm Spanner	1
25	Safety Throttle Lever	1	49	Pin Wrench	1
26	Spring Pin	1	50	5mm Hex. Wrench	1
28	Exhaust Deflector	1	51	8mm Hex. Wrench (For 5/8-11 & M16×P2.0 Spindle)(Option)	1
29	Valve Seat	1	52	6mm Hex. Wrench (M14×P2.0)	1
30	Valve Stem	1			
31	Spring	1			
32	Air Inlet (3/8NPT18)	1			
	Air Inlet (3/8PT19)				
	Air Inlet (3/8PF19)				

0000.00.00

2015.06.11 2018.05.14